

FOSCARINI

Collezioni

Foscarini è nata da un'intuizione di Carlo Urbinati e Alessandro Vecchiato ed è cresciuta grazie alla passione, all'energia ed al talento di tutti coloro che ci hanno lavorato e ci lavorano.

Foscarini was born from an intuition of Carlo Urbinati and Alessandro Vecchiato and has grown thanks to the passion, energy and talent of all the people that have worked and are working for it.

—
**33 designer, 20
materiali, 46
finiture,
18 tecnologie,
31 colori, 55 famiglie
di lampade, 201
modelli diversi.**

—
**33 designers, 20
materials, 46
finishes,
18 technologies,
31 colours, 55 lamps
families, 201
different models.**

Indice alfabetico — *Alphabetical index*

- | | | | |
|-------------------------------|----------------------------------|-------------------------------|---------------|
| 136 Allegretto | 240 Caboche <i>ceiling</i> | 308 Innerlight | 338 Solar |
| 134 Allegro | 076 Caboche <i>floor</i> | | 190 Spokes |
| 020 Anisha | 152 Caboche <i>susp.</i> | 310 Kite | 108 Stewie |
| 072 Aplomb <i>floor</i> | 154 Caboche <i>piccola susp.</i> | 168 Jamaica | 192 Supernova |
| 138 Aplomb <i>susp</i> | 030 Caboche <i>table</i> | | |
| 264 Aplomb <i>wall</i> | 284 Caboche <i>wall</i> | 194 Tite | |
| | 156 Chouchin | 258 Tivu <i>ceiling</i> | |
| 230 Bahia <i>ceiling</i> | 158 Chouchin <i>mini</i> | 322 Tivu <i>wall</i> | |
| 272 Bahia <i>wall</i> | 160 Chouchin <i>reverse</i> | 110 Tress <i>floor</i> | |
| 232 Bahia <i>Mini ceiling</i> | 242 Circus <i>ceiling</i> | 196 Tress <i>susp.</i> | |
| 274 Bahia <i>Mini wall</i> | 286 Circus <i>wall</i> | 198 Tress <i>grande susp.</i> | |
| 140 Behive <i>susp.</i> | 078 Colibri | 062 Tress <i>table</i> | |
| 022 Behive <i>table</i> | | 324 Tress <i>wall</i> | |
| 234 Big Bang <i>ceiling</i> | 032 Doll | 112 Tress <i>Stilo floor</i> | |
| 146 Big Bang <i>susp.</i> | 288 Double | 200 Tress <i>Stilo susp.</i> | |
| 276 Big Bang <i>wall</i> | | 202 Troag | |
| 024 Binic | 244 Ellepi <i>ceiling</i> | 204 Tropico | |
| 236 Birdie <i>ceiling</i> | 290 Ellepi <i>wall</i> | 118 Tuareg | |
| 074 Birdie <i>floor</i> | 034 Esa | 326 Tutù | |
| 028 Birdie <i>Metal</i> | | 260 Twiggy <i>ceiling</i> | |
| 026 Birdie <i>table</i> | 246 Falena <i>ceiling</i> | 124 Twiggy <i>floor</i> | |
| 278 Birdie <i>wall</i> | 292 Falena <i>wall</i> | 126 Twiggy <i>Lettura</i> | |
| 280 Bit | 298 Fields | 206 Twiggy <i>susp.</i> | |
| 238 Blob <i>ceiling</i> | 300 Flip | 064 Twiggy <i>xl table</i> | |
| 282 Blob <i>wall</i> | 248 Folio <i>ceiling</i> | | |
| | 302 Folio <i>wall</i> | 208 Uto <i>susp.</i> | |
| | | 066 Uto <i>table</i> | |
| | 080 Giga-Lite <i>floor</i> | 340 Uto <i>outdoor</i> | |
| | 162 Giga-Lite <i>susp.</i> | | |
| | 250 Gregg <i>ceiling</i> | 210 Wave | |
| | 082 Gregg <i>floor</i> | | |
| | 164 Gregg <i>susp.</i> | 068 Yoko | |
| | 036 Gregg <i>table</i> | | |
| | 304 Gregg <i>wall</i> | | |
| | 332 Gregg <i>outdoor floor</i> | | |
| | 330 Gregg <i>outdoor susp.</i> | | |
| | | 106 Orbital | |
| | 088 Havana <i>floor</i> | 178 O-Space | |
| | 166 Havana <i>susp.</i> | | |
| | 306 Havana <i>wall</i> | 180 Planet | |
| | 336 Havana <i>outdoor floor</i> | 182 Plass <i>grande susp.</i> | |
| | 334 Havana <i>outdoor susp.</i> | 184 Plass <i>media susp.</i> | |
| | | 050 Plass <i>media table</i> | |
| | | 052 Poly Gregg | |
| | | 256 Rituals <i>ceiling</i> | |
| | | 186 Rituals <i>susp.</i> | |
| | | 058 Rituals <i>table</i> | |
| | | 320 Rituals <i>wall</i> | |
| | | 188 Rituals <i>xl susp.</i> | |
| | | 060 Rituals <i>xl table</i> | |

Indice delle categorie — *Category index*Tavolo — *Table*

p. 018 → p. 069

Terra — *Floor*

p. 070 → p. 127

Sospensione — *Suspension*

p. 128 → p. 211

Accessori — *Accessories*

p. 212 → p. 227

Soffitto — *Ceiling*

p. 228 → p. 261

Parete — *Wall*

p. 262 → p. 327

Esterno — *Outdoor*

p. 328 → p. 341

Legenda — *Key*

p. 354

Tavolo — *Table* →

Anisha
Lievore Altherr
Molina, 2011
→ p. 020



Behive
Werner Aisslinger, 2011
→ p. 022



Poly Gregg
L+R Palomba, 2011
→ p. 052



Rituals
L+R Palomba, 2013
→ p. 058



Rituals xl
L+R Palomba, 2015
→ p. 060



Tress
Marc Sadler, 2009
→ p. 062



Binic
Ionna Vautrin, 2010
→ p. 024



Birdie
L+R Palomba, 2011
→ p. 026



Birdie Metal
L+R Palomba, 2014
→ p. 028



Caboche
Urquiola + Gerotto, 2005
→ p. 030

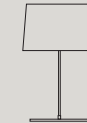

Twiggy xl
Marc Sadler, 2008
→ p. 064



Uto
Lagranja Design, 2005
→ p. 066



Yoko
Anderssen & Voll, 2013
→ p. 068



Doll
Ionna Vautrin, 2012
→ p. 032

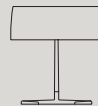

Esa
Lievore Altherr
Molina, 1996
→ p. 034



Gregg
L+R Palomba, 2007
→ p. 036



Lumiere
Rodolfo Dordoni, 1990
→ p. 042

Terra — *Floor* →

Aplomb
Lucidi e Pevere, 2015
→ p. 072



Birdie
L+R Palomba, 2011
→ p. 074



Lumiere 25th
Rodolfo Dordoni, 1990/2015
→ p. 044



Lumiere xxl + xxs
Rodolfo Dordoni, 2009
→ p. 046



Magneto
Giulio Iacchetti, 2011
→ p. 048



Plass media
Luca Nichetto, 2015
→ p. 050



Caboche
Urquiola + Gerotto, 2005
→ p. 076



Colibri
Odoardo Fioravanti, 2011
→ p. 078



Giga-Lite
Marc Sadler, 2004
→ p. 080



Gregg
L+R Palomba, 2010
→ p. 082

Indice generale — *Product's overview*

Havana
Joseph Forakis, 1993
→ p. 088



Lightwing
Jean Marie Massaud, 2014
→ p. 090



Magneto
Giulio Iacchetti, 2011
→ p. 092



Mite
Marc Sadler, 2000
→ p. 100



Orbital
Ferruccio Laviani, 1992
→ p. 106



Stewie
Luca Nichetto, 2012
→ p. 108



Tress
Marc Sadler, 2008
→ p. 110



Tress Stilo
Marc Sadler, 2011
→ p. 112

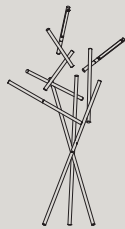

Tuareg
Ferruccio Laviani, 2014
→ p. 118

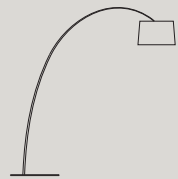

Twiggy
Marc Sadler, 2006
→ p. 124

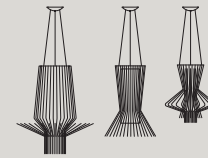

Twiggy lettura
Marc Sadler, 2008
→ p. 126

Lampade da terra e da sospensione — *Floor and suspension lamps*

Allegretto
Atelier Oi, 2009
→ p. 136

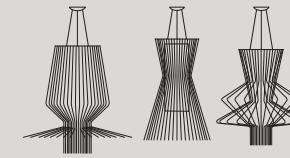

Allegro
Atelier Oi, 2007
→ p. 134



Aplomb
Lucidi e Pevere, 2010
→ p. 138



Behive
Werner Aisslinger, 2012
→ p. 140



Big Bang
Franzolini + Garcia Jimenez, 2005
→ p. 146



Caboche grande + media
Urquiola + Gerotto, 2005
→ p. 152



Caboche piccola
Urquiola + Gerotto, 2005
→ p. 154

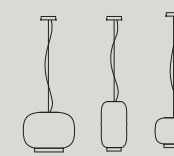

Chouchin
Ionna Vautrin, 2011
→ p. 156

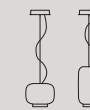

Chouchin mini
Ionna Vautrin, 2013
→ p. 158

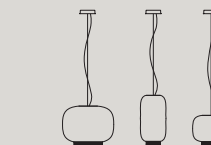

Chouchin Reverse
Ionna Vautrin, 2015
→ p. 160



Giga-Lite
Marc Sadler, 2004
→ p. 162



Gregg
L+R Palomba, 2007
→ p. 164



Havana
Joseph Forakis, 1993
→ p. 166



Jamaica
Marc Sadler, 2011
→ p. 168



Le Soleil
Vicente Garcia Jimenez, 2009
→ p. 170



Lightweight
Tom Dixon, 1995
→ p. 172

Indice generale — *Product's overview*

Maki
Nendo, 2011
→ p. 174

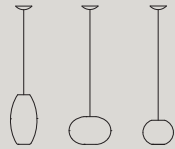

New Buds
Rodolfo Dordoni, 2007
→ p. 176



O-space
Nichetto e Gai, 2003
→ p. 178



Planet
Changedesign, 2011
→ p. 180



Plass grande
Luca Nichetto, 2011
→ p. 182



Plass media
Luca Nichetto, 2015
→ p. 184

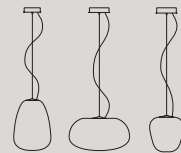

Rituals
L+R Palomba, 2013
→ p. 186



Rituals xl
L+R Palomba, 2015
→ p. 188



Spokes
Garcia Cumini, 2015
→ p. 190



Supernova
Ferruccio Laviani, 2000
→ p. 192



Tite
Marc Sadler, 2000
→ p. 194



Tress
Marc Sadler, 2009
→ p. 196



Tress grande
Marc Sadler, 2009
→ p. 198



Tress stilo
Marc Sadler, 2011
→ p. 200

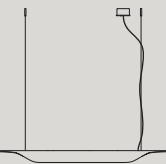

Troag
Luca Nichetto, 2010
→ p. 202



Tropico
Giulio Iacchetti, 2008
→ p. 204

Lampade da sospensione, accessori — *Suspension lamps, accessories*

Twiggy
Marc Sadler, 2007
→ p. 206



Uto
Lagranja Design, 2005
→ p. 208



Wave
Baruffi & De Santi, 2009
→ p. 210

Accessori — Accessories →



Rosone multiple tondo
Round multiple canopy
→ p. 214



Rosone multiple lineare piccolo
Small linear multiple canopy
→ p. 218

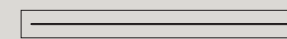

Rosone multiple lineare grande
Large linear multiple canopy
→ p. 222

Kit decentramento
Decentralization kit
→ p. 226

Soffitto — Ceiling →



Bahia
L+R Palomba, 2010
→ p. 230

Indice generale — *Product's overview*

Bahia mini
L+R Palomba, 2015
→ p. 232

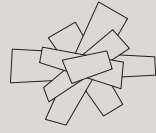

Big Bang
Franzolini + Garcia Jimenez, 2006
→ p. 234

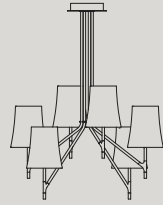

Birdie 1 - 3 - 6 - 9
L+R Palomba, 2012
→ p. 236



Blob S
Karim Rashid, 2002
→ p. 238

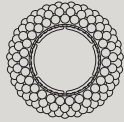

Caboche
Urquiola + Gerotto, 2006
→ p. 240



Circus
Defne Koz, 1994
→ p. 242

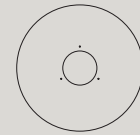

Ellepi
Alessandra Matilde, 2003
→ p. 244

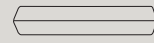

Falena
Lucidi e Pevere, 2011
→ p. 246



Folio
Urbinati + Vecchiato, 1990
→ p. 248



Gregg
L+R Palomba, 2007
→ p. 250



Lumiere xxl + xxs
Rodolfo Dordoni, 2010
→ p. 252

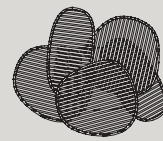

Nuage
Philippe Nigro, 2012
→ p. 254



Blob S
Karim Rashid, 2002
→ p. 282

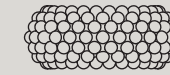

Caboche
Urquiola + Gerotto, 2006
→ p. 284



Circus
Defne Koz, 1994
→ p. 286



Double
Valerio Bottin, 1996
→ p. 288



Rituals
L+R Palomba, 2015
→ p. 256

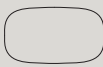

Tivu
Jozeph Forakis, 2011
→ p. 258



Twiggy
Marc Sadler, 2007
→ p. 260

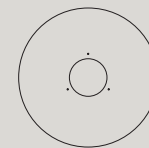

Ellepi
Alessandra Matilde, 2003
→ p. 290

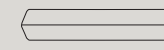

Falena
Lucidi e Pevere, 2011
→ p. 292

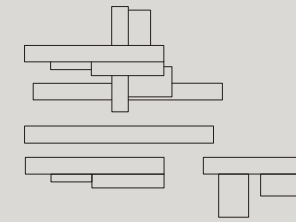

Fields
Vicente Garcia Jimenes, 2007
→ p. 298



Flip
Simon Pengelly, 2013
→ p. 300

Lampade da soffitto e da parete — *Ceiling and wall lamps*Parete — *Wall* →

Aplomb
Lucidi e Pevere, 2014
→ p. 264



Bahia
Lucidi e Pevere, 2010
→ p. 272



Bahia mini
Lucidi e Pevere, 2015
→ p. 274

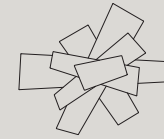

Big Bang
Franzolini + Garcia Jimenez, 2006
→ p. 276

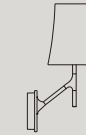

Birdie
L+R Palomba, 2012
→ p. 278

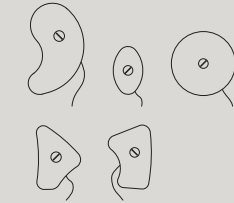

Bit
Ferruccio Laviani, 1993
→ p. 280



Blob S
Karim Rashid, 2002
→ p. 282



Caboche
Urquiola + Gerotto, 2006
→ p. 284



Circus
Defne Koz, 1994
→ p. 286



Double
Valerio Bottin, 1996
→ p. 288

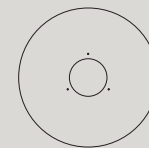

Ellepi
Alessandra Matilde, 2003
→ p. 290

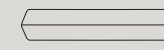

Falena
Lucidi e Pevere, 2011
→ p. 292

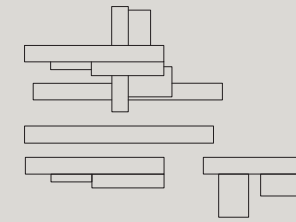

Fields
Vicente Garcia Jimenes, 2007
→ p. 298



Flip
Simon Pengelly, 2013
→ p. 300

Indice generale — *Product's overview*

Folio
Urbinati + Vecchiato, 1990
→ p. 302



Gregg
L+R Palomba, 2007
→ p. 304



Havana
Jozeph Forakis, 1993
→ p. 306

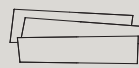

Innerlight
Simon Pengelly, 2012
→ p. 308



Kite
Marc Sadler, 2003
→ p. 310



Lake
Lucidi e Pevere, 2015
→ p. 312

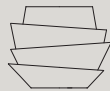

Le Soleil
Vicente Garcia Jimenes, 2013
→ p. 314



Lumiere xxl + xxs
Rodolfo Dordoni, 2010
→ p. 316

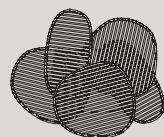

Nuage
Philippe Nigro, 2012
→ p. 318



Rituals
L+R Palomba, 2015
→ p. 320



Tivu
Jozeph Forakis, 2011
→ p. 322



Tress
Marc Sadler, 2011
→ p. 324



Tutù
Valerio Bottin, 2001
→ p. 326

Lampade da parete e da esterno — *Wall and outdoor lamps*

Gregg Outdoor sospensione
L+R Palomba, 2013
→ p. 330

Esterno — *Outdoor* →

Gregg Outdoor terra
L+R Palomba, 2011
→ p. 332



Havana Outdoor Sospensione
Jozeph Forakis, 2005
→ p. 334

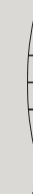

Havana Outdoor Terra
Jozeph Forakis, 2005
→ p. 336



Solar Outdoor
Jean Marie Massaud, 2011
→ p. 338



Uto
Lagranja Design, 2005
→ p. 340

Nota sulle lampade LED — *Note on LED lamps*

LED — Identifica i modelli con LED integrati e già inclusi, risultato della progettazione ed ingegnerizzazione Foscarini.

LED Retrofit — Identifica la possibilità di utilizzare una lampadina LED retrofit standard comunemente disponibile sul mercato.

LED — It marks the models with integrated LED included in the lamp, which is the result of Foscarini designing and engineering.

LED Retrofit — It marks the possibility of using a standard retrofit LED bulb available on the market.

Prima che sia luce

— *Before there is light*

photography by

Gianluca Vassallo





ore 8.00
h 8 am

Good morning

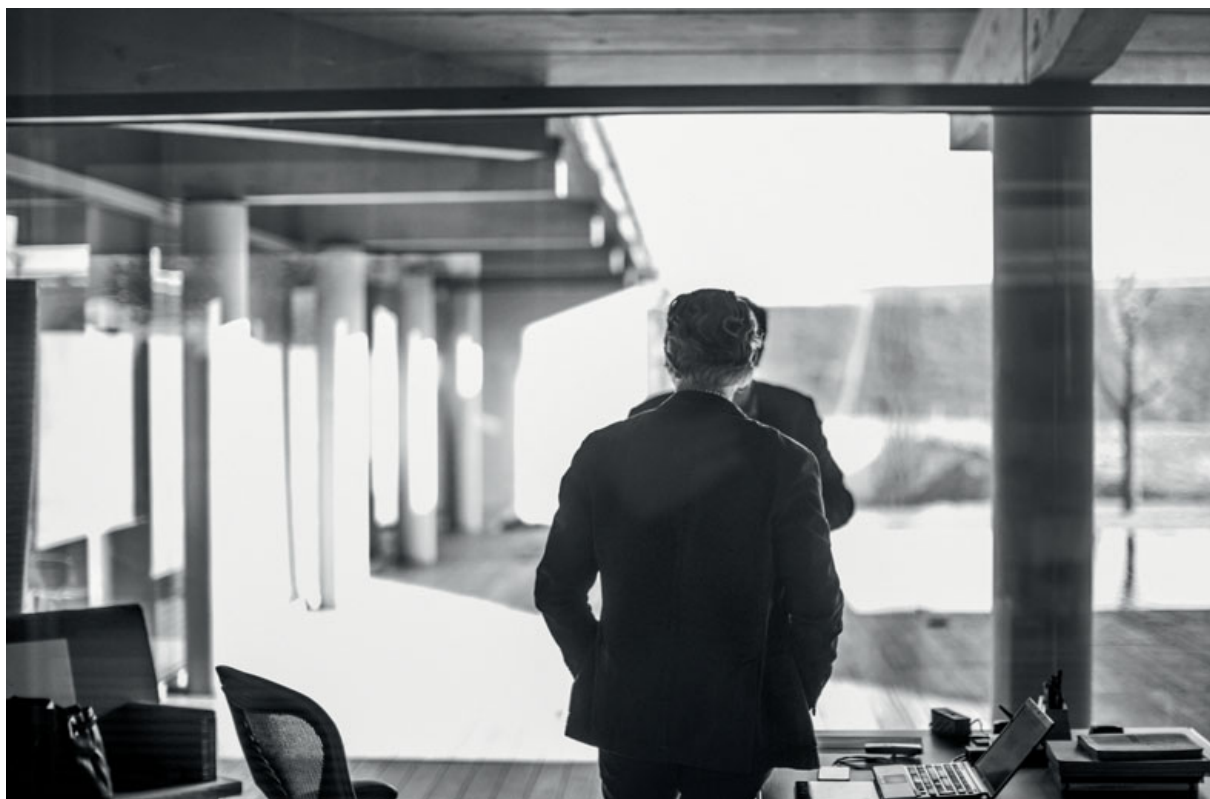

ore 8.30
h 8.30 am

Headquarters



ore 9.00
L'innovazione nasce dall'incontro.
h 9 am *It is from a meeting
of minds that innovation emerges.*

Conference

ore 9.20
h 9.20 am



Meeting



ore 10.00
h 10 am



ore 10.45
h 10.45 am

Technical department

Headquarters



ore 11.15
I pensieri prendono forma.
h 11.15 am *Thoughts take
shape.*

Technical department



ore 12.00
L'ombra, l'altra faccia della luce.
h 12 am *Shade, the other face
of light.*

ore 14.15
Provare per credere.
h 2.15 pm Seeing
is believing.





ore 14.30
Immaginare la luce.
h 2.30 pm *Imagine*
the light.



Design Factory

Quality

ore 15.15

Creare con le proprie mani.

h 3.15 pm *Creating with
our own hands.*

Prototypes



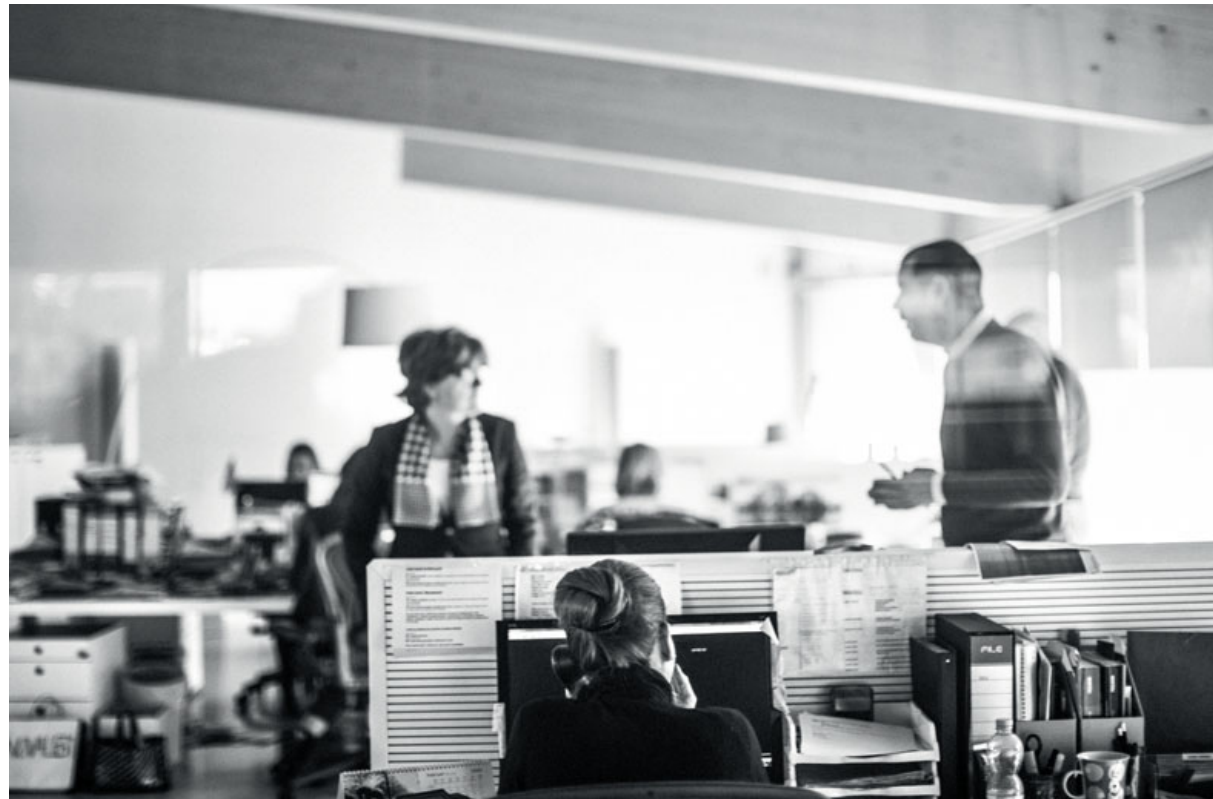

ore 15.30
Connessi con il mondo.
h 3.30 pm *Connected with
the world.*

Commercial department

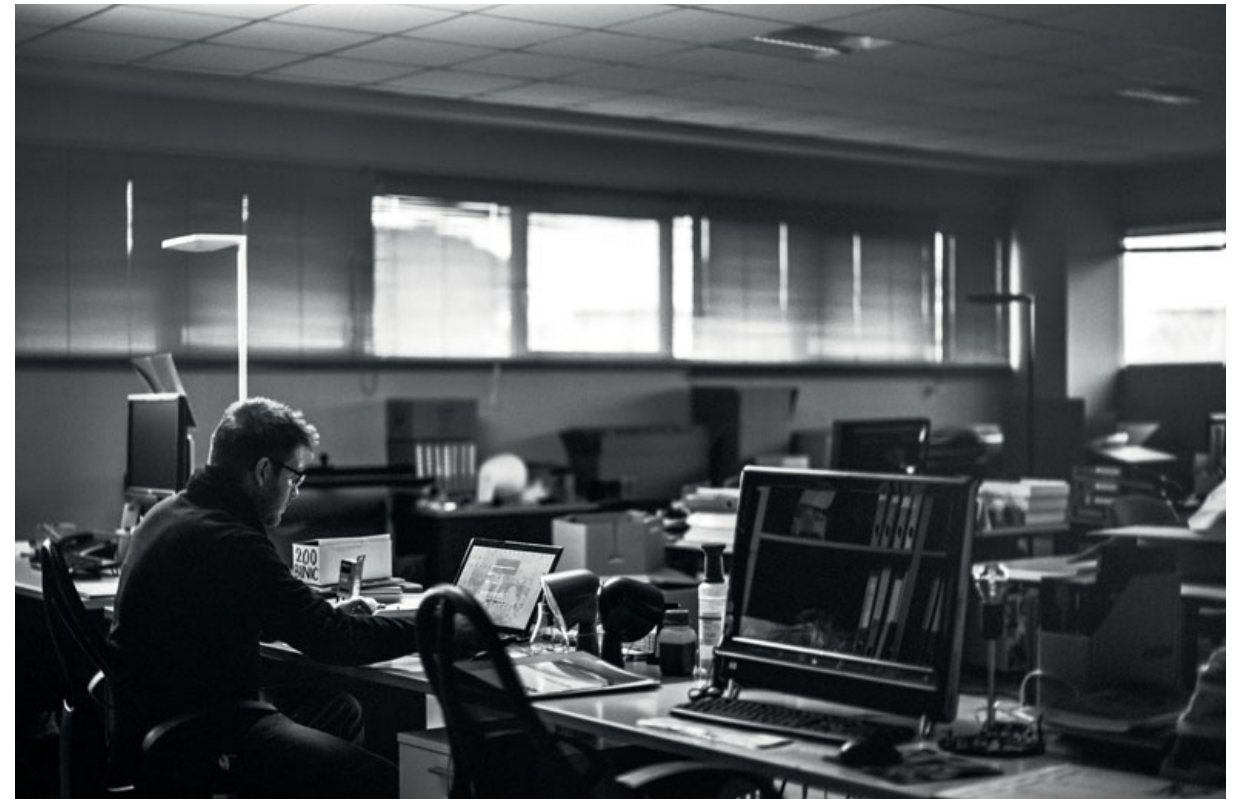

Technical department



ore 15.45
Una ricerca continua.
h 3.45 pm Ongoing
research.

ore 16.15
h 4.15 pm

Warehouse



ore 16.15
Made in Foscarni.
h 4.15 pm Made
in Foscarni.

Assembling



ore 17.00
Passaggio di mano.
h 5 pm Handover.

Assembling



Warehouse

ore 17.30
Tutto è pronto
per domani.
h 5.30 pm *Everything*
is ready for tomorrow.



Latitudine, *Latitude*:
N 45° 33' 42''
Longitudine, *Longitude*:
E 12° 17' 53''
Altitudine, *Altitude*:
4 mt. s.l.m.
Indirizzo, *Address*:
via delle Industrie 27
Marcon, Venezia, Italia



Tavolo — *Table*

- | | | | |
|-----|--------------------------------|-----|--------------------|
| 020 | Anisha | 048 | Magneto |
| 022 | Behive | 050 | Plass media |
| 024 | Binic | 052 | Poly Gregg |
| 026 | Birdie | 054 | Rituals |
| 028 | Birdie Metal | 060 | Rituals xl |
| 030 | Caboche | 062 | Tress |
| 032 | Doll | 064 | Twiggy xl |
| 034 | Esa | 066 | Uto |
| 036 | Gregg | 068 | Yoko |
| 038 | Lumiere | | |
| 044 | Lumiere 25th | | |
| 046 | Lumiere xxl | | |
| | + xxs | | |

Anisha

Studio Lievore Altherr Molina, 2011

LED

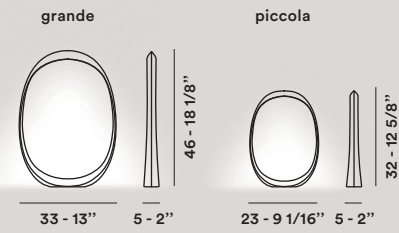

ABS stampato a iniezione.
Injection moulded ABS.

Anisha grande
LED 4,5W 3000° K 400 lm included
Energy class A+

Anisha piccola
LED 3,4W 3000° K 300 lm included
Energy class A+

Touch-dimmer incluso
Touch-dimmer included

IP 20

Bianco, rosso.
White, red.



Behive

Werner Aisslinger, 2011

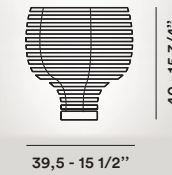

ABS masterizzato, policarbonato e metallo verniciato.
Batch-dyed ABS, polycarbonate and varnished metal.

220 / 240V: halo 1x150W E27
120V: halo 1x150W E26
Energy class C

Dimmer incluso — *Dimmer included*



Bianco. *White.*



collection →



Binic

Ionna Vautrin, 2010

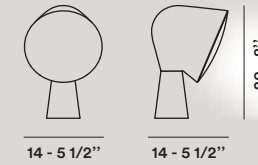

ABS masterizzato e policarbonato.
Polycarbonate and batch-dyed ABS.

LED E14/E12

220 / 240V: fluo 1x12W E14
120V: fluo 1x13W E12
Energy class A+, A

IP 20

Bianco, rosa, verde acqua, blu, giallo, grigio.
White, pink, turquoise green, blue, yellow, grey.

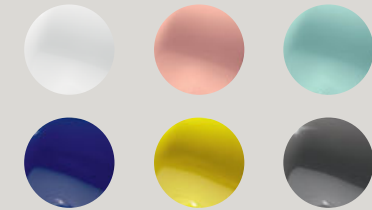

Birdie

Ludovica e Roberto Palomba, 2011



grande

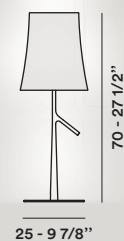

piccola



Polycarbonato, acciaio e metallo verniciati.
Polycarbonate, varnished steel and metal.

LED E27/E26
on/off version only

Birdie grande
220 / 240V: halo 1x150W E27, fluo 1x25W E27
120V: halo 1x150W E26, fluo 1x26W E26
Energy class A+, A, B, C

Birdie piccola
220 / 240V: halo 1x70W E27, fluo 1x20W E27
120V: halo 1x70W E26, fluo 1x20W E26
Energy class A+, A, B, C

Touch-dimmer incluso
Touch-dimmer included



Bianco, grigio, arancio, amaranto.
White, grey, orange, amaranth.

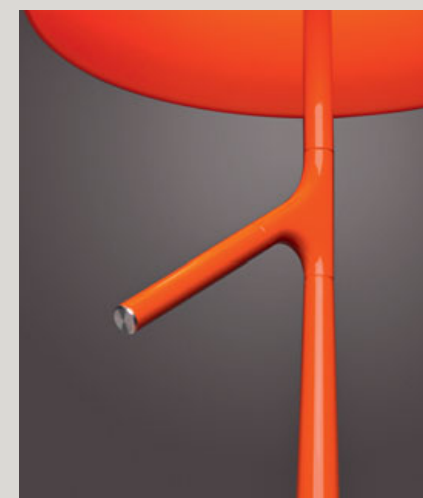

collection →

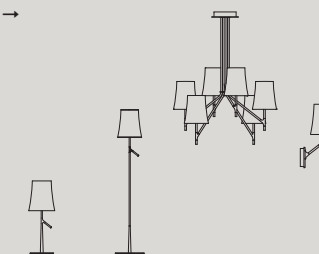

p. 028 p. 074 p. 236 p. 278



Birdie Metal

Ludovica e Roberto Palomba, 2014



grande

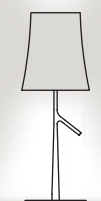

25 - 9 7/8"

piccola

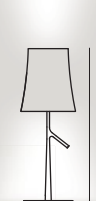

17 - 6 3/4"

Policarbonato e acciaio metallizzati.
Metallized polycarbonate and metallized steel.

LED E27/E26

Birdie grande
220 / 240V: fluo 1x25W E27
120V: fluo 1x26W E26
Energy class A+, A

Birdie piccola
220 / 240V: fluo 1x20W E27
120V: fluo 1x20W E26
Energy class A+, A



Cromo nero, rame.
Black chrome, copper.

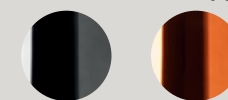

collection →

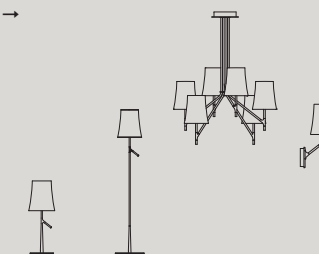

p. 026 p. 074 p. 236 p. 278



Caboche

Patricia Urquiola con Eliana Gerotto, 2005

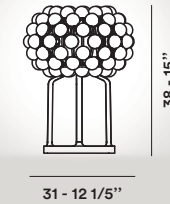

Polimetilmetacrilato, vetro soffiato e alluminio verniciato.
PMMA, blown glass and varnished aluminium.

220 / 240V: halo 1x48W G9
120V: halo 1x60W G9
Energy class C

220 / 240V: Dimmer incluso — *Dimmer included*

IP 20

Trasparente, giallo oro.
Transparent, gold yellow.

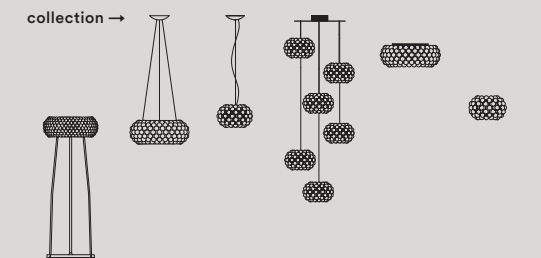

p. 076 p. 152 p. 154 p. 214 p. 240 p. 284





Doll

Ionna Vautrin, 2012

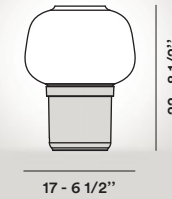

Vetro soffiato, ABS masterizzato e policarbonato.
Blown glass, batchdyed ABS and polycarbonate.

LED E14/E12

220 / 240V: fluo 1x12W E14
120V: fluo 1x13W E12
Energy class A+, A

IP 20

Avorio, grigio, verde, rosso.
Ivory, grey, green, red.

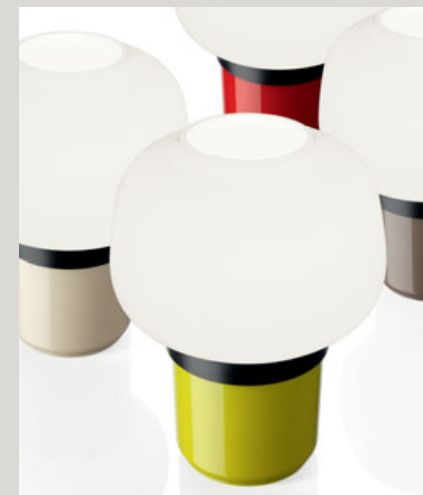



Esa

Lievore Asociados, 1996

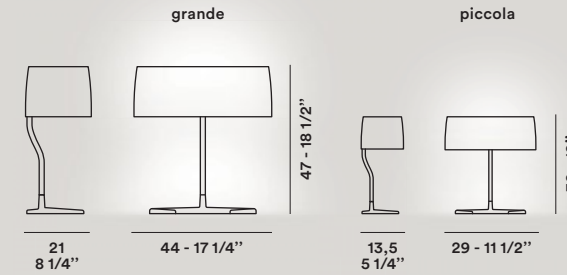

Vetro soffiato e alluminio spazzolato.
Blown glass and polished aluminium.

Esa grande
LED E27/E26

220 / 240V: halo 1x77W E27,
fluo 1x20W E27
120V: inc 1x100W E26,
fluo 1x20W E26
Energy class A+, A, B, C

Esa piccola
220 / 240V: halo 1x33W G9
120V: halo 1x40W G9
Energy class C

Esa piccola
Dimmer incluso — *Dimmer included*

☐ IP 20

Bianco. *White.*



Gregg

Ludovica e Roberto Palomba, 2007

grande

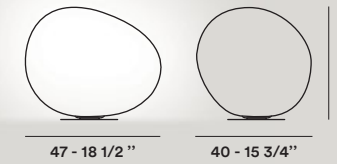

media

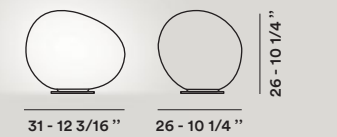

piccola



Vetro soffiato acidato e metallo verniciato.
Blown acid-etched glass and varnished metal.

Gregg grande
220 / 240V: halo 1x205W E27
120V: halo 1x150W E26
Energy class C

Gregg media
220 / 240V: halo 1x150W E27
120V: halo 1x100W E26
Energy class C

Gregg piccola
220 / 240V: halo 1x20W G9
120V: halo 1x25W G9
Energy class C

Dimmer incluso — *Dimmer included*



Bianco. *White.*

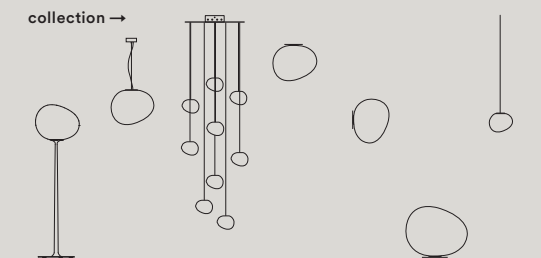
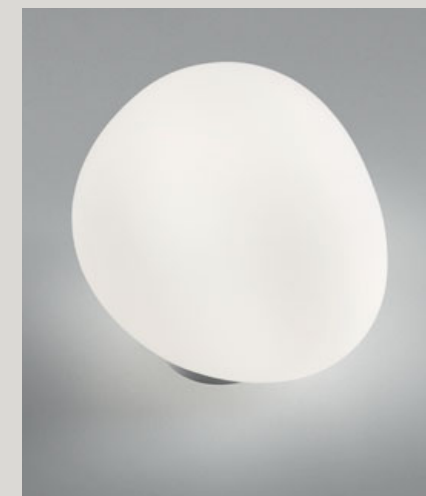

p. 082 p. 164 p. 214 p. 250 p. 304 p. 332 p. 330



Lampada da tavolo — *Table lamp*



Lumiere

Rodolfo Dordoni, 1990

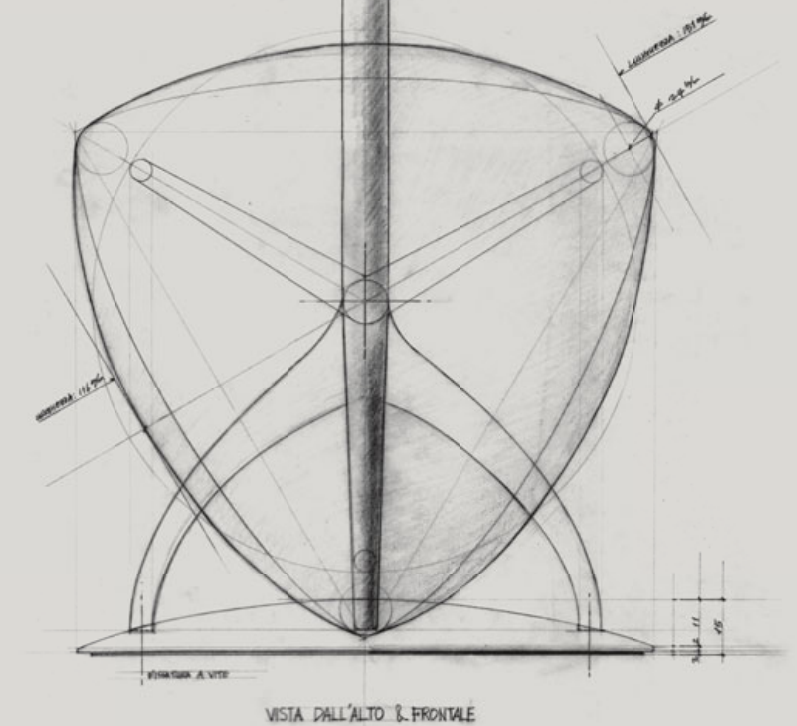

Lumiere, imperdibile best-seller.

L'abat-jour nasce nel XVII secolo a Parigi e da allora, fino ai giorni nostri, ha attraversato innumerevoli interpretazioni. Poi nel 1990, dall'incontro fra un designer e un'azienda italiani, nasce un'idea nuova nel mondo dell'illuminazione: Lumiere.

Lumiere, a must-have best-seller.

The bedside lamp was invented in Paris during the 17th Century and it has undergone a myriad interpretations ever since. In 1990, a meeting between a designer and an Italian company gave rise to a brand new idea in the lighting industry, namely Lumiere.

Best-seller

Lumiere — Rodolfo Dordoni, 1990

Una rilettura colta e raffinata della classica abat-jour, con un prezioso diffusore in vetro soffiato, unito a un inconfondibile treppiede in alluminio pressofuso. Nel 25° anniversario della sua creazione, Lumiere si presenta in un'edizione speciale, con un trattamento metallizzato del vetro che fa intravedere magicamente la sorgente luminosa all'interno.

It is a learned and sophisticated restyling of the classic bedside lamp, with a precious blown glass diffuser, combined with an unmistakable tripod in die-cast aluminium. On the 25th anniversary of its creation, Lumiere is proposed in a special edition, with a metallic treatment of the glass that lets you catch a glimpse of the light source inside.

Elegance

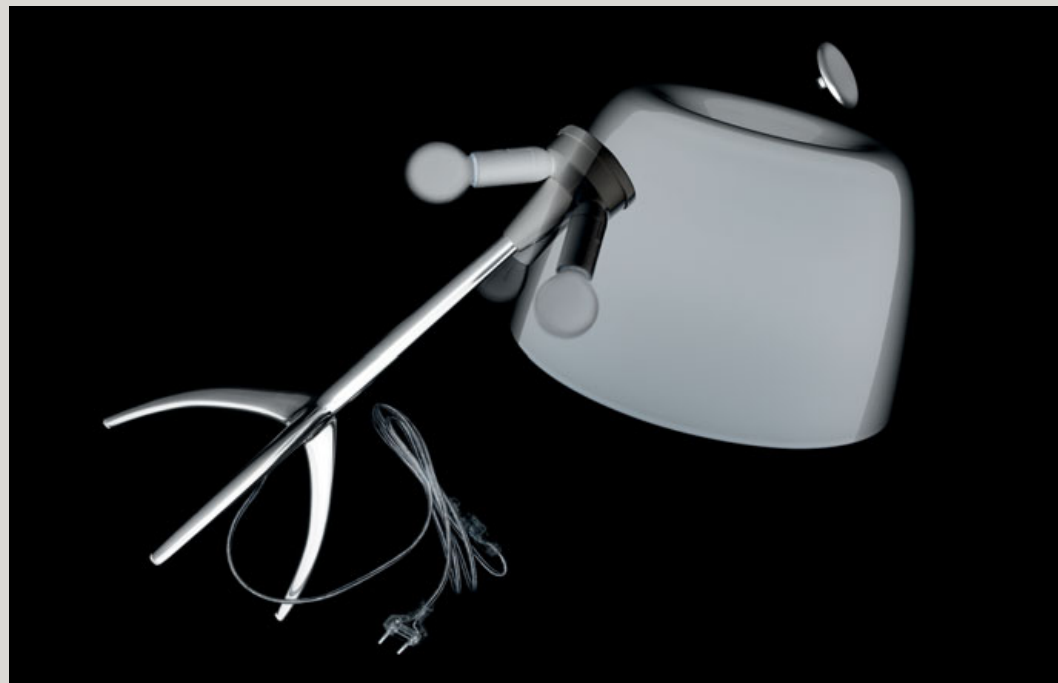

Prototipo — Prototype

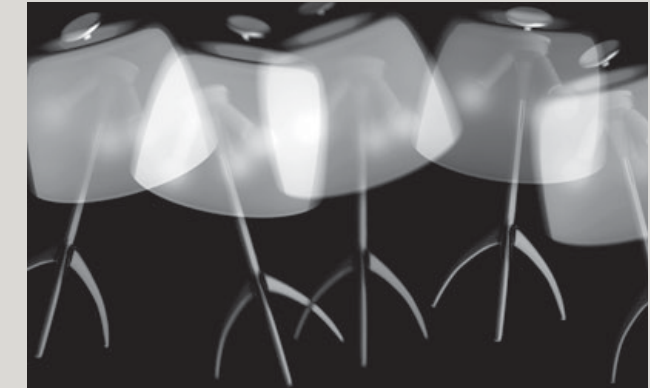

Anche il modello originario aggiunge un nuovo colore alla base e tre nuove tonalità per il diffusore, con un trattamento nella parte interna del vetro che rende la luce ancora più morbida e calda. Nuovi colori per base e diffusore anche per le versioni XXL e XXS. Lumiere ha sempre una storia splendida e diversa da raccontare.

The original model has also been supplemented with a new colour for the base and three new shades for the diffuser, with a special treatment in the inner side of the glass that makes the light it casts even warmer and softer. New base and diffuser colours for the XXL and XXS versions too. Lumiere always has a different yet spectacular tale to tell.

Textes en français, Deutsche Texte, Textos en español → p. 343

25th Anniversary

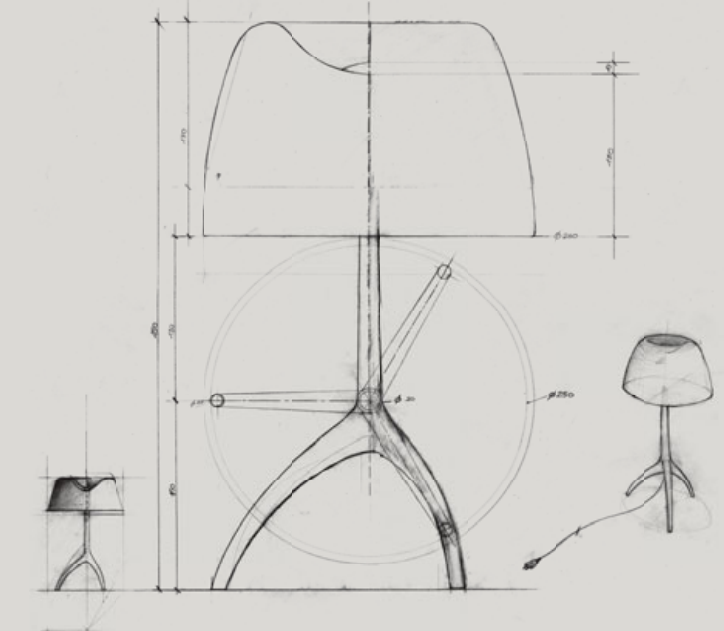
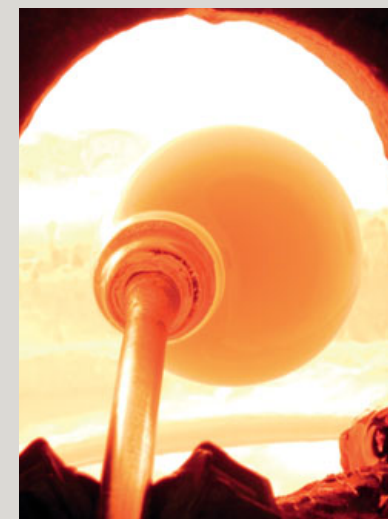

Lumiere

Rodolfo Dordoni, 1990

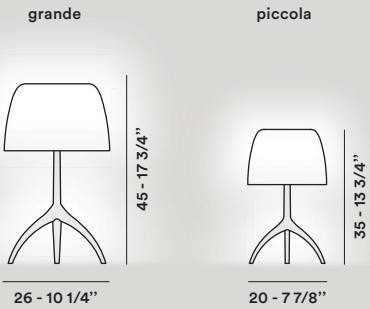

Vetro soffiato e alluminio spazzolato o verniciato.
Blown glass and polished or varnished aluminium.

Lumiere grande
220 / 240V: halo 2x48W G9
120V: inc 2x40W G9
Energy class C

Lumiere piccola
220 / 240V: halo 1x48W G9
120V: halo 1x40W G9
Energy class C

IP 20 — (piccola)

Vetro: bianco, bianco caldo, ciliegia, turchese.
Glass: white, warm white, cherry, turquoise.
Montatura: alluminio spazzolato, cromo nero, champagne.
Frame: polished aluminium, black chrome, champagne.

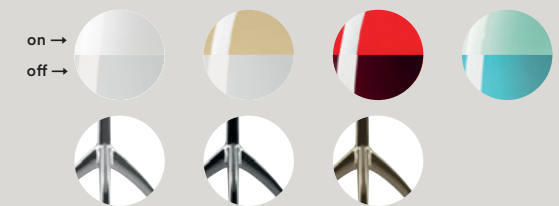

collection →



Lumiere 25th

Rodolfo Dordoni, 1990/2015

grande

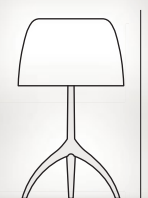

26 - 10 1/4"

45 - 17 3/4"

piccola



20 - 7 7/8"

35 - 13 3/4"

Vetro soffiato e specchiato e alluminio spazzolato o verniciato.
Blown mirrored glass and polished or varnished aluminium.

Lumiere 25th grande
220 / 240V: halo 3x30W E14
120V: inc 3x40W E12
Energy class C

Lumiere 25th piccola
220 / 240V: halo 1x48W G9
120V: halo 1x40W G9
Energy class C

☐ ⚡ IP 20 - © (piccola)

Vetro: specchio trasparente.
Glass: transparent mirror.
Montatura: alluminio spazzolato, cromo nero, champagne.
Frame: polished aluminium, black chrome, champagne.



collection →



p. 042





Lumiere xxl + xxs

Rodolfo Dordoni, 2009

Lumiere xxl



Lumiere xxs



Vetro soffiato e alluminio spazzolato o cromo nero.
Blown glass and polished aluminium or black chrome.

Lumiere xxl
220 / 240V: halo 3x48W G9
120V: halo 3x60W G9
Energy class C

Lumiere xxs
220 / 240V: halo 1x48W G9
120V: halo 1x40W G9
Energy class C

Dimmer incluso — *Dimmer included*

☐ ⚡ IP 20

Vetro: bianco, grigio ghiaccio, marrone.
Glass: white, cool grey, brown.
Montatura: alluminio spazzolato, cromo nero.
Frame: polished aluminium, black chrome.

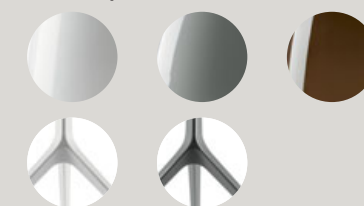

collection →



Magneto

Giulio Iacchetti, 2011

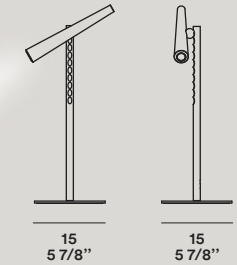

Acciaio verniciato opaco, ABS e supermagnete in terre rare.
Matt varnished steel, ABS and super magnet made of "rare earth".

LED 5W 2700° K 475 lm included
Energy class A+

IP 20

Bianco, nero.
White, black.



collection →



p. 092



Plass media

Luca Nichetto, 2015

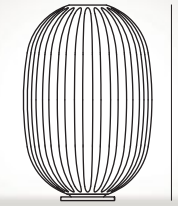

34 - 13 1/4"

51 - 20"

Policarbonato stampato in rotazionale e acciaio.
Rotational moulded polycarbonate and steel.

LED E27/E26
on/off version only

220 / 240V: halo 1x150W E27,
120V: halo 1x150W E27,
Energy class A+, A, B, C

Dimmer incluso — *Dimmer included*

IP 20

Azzurro, grigio.
Light blue, grey.

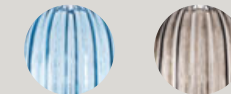

collection →

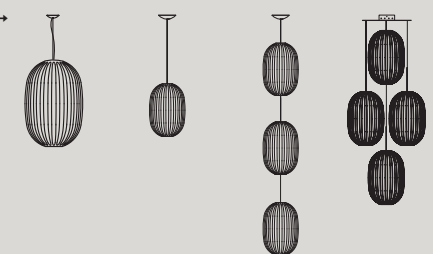

p. 182

p. 184

p. 184

p. 214



Poly Gregg

Ludovica e Roberto Palomba, 2011



X-large

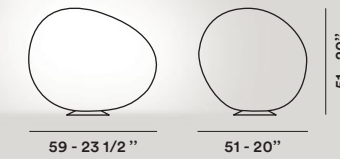

grande

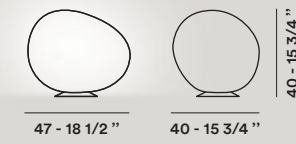

media

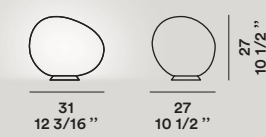

Polietilene stampato in rotazionale.
Rotational moulded polyethylene.

LED E27/E26

Poly Gregg X-large - grande
220 / 240V: fluo 1x25W E27
120V: fluo 1x26W E26
Energy class A+, A

Poly Gregg media
220 / 240V: fluo 1x15W E27
120V: fluo 1x15W E26
Energy class A+, A

IP 20

Bianco. *White.*

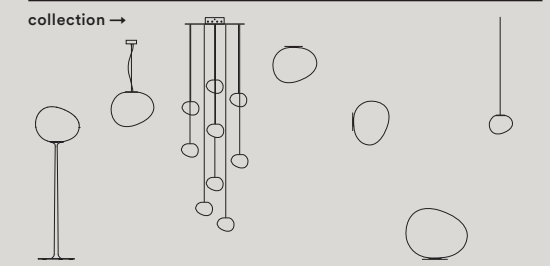

p. 082 p. 164 p. 214 p. 250 p. 304 p. 332 p. 330





055

Lampada da tavolo, sospensione, parete e soffitto — *Table, suspension, wall and ceiling lamp*

Rituals

Ludovica e Roberto Palomba, 2013

Rituals, lanterne moderne. Ispirate nella forma alle leggere lanterne di carta di riso della cultura orientale, ma realizzate in prezioso vetro soffiato, materiale di millenaria tradizione occidentale, le lampade Rituals parlano un linguaggio senza tempo e senza confini: quello della bellezza, della poeticità e della libertà d'abbinamento e ambientazione.

Rituals, modern lanterns. Inspired by the shape of light-weight rice paper lanterns from the Oriental culture, yet made in precious blown glass, a material with a thousand-year Western tradition. The Rituals lamps speak a timeless language without boundaries: the language of beauty, poetry, and freedom of combination and setting.

Magical



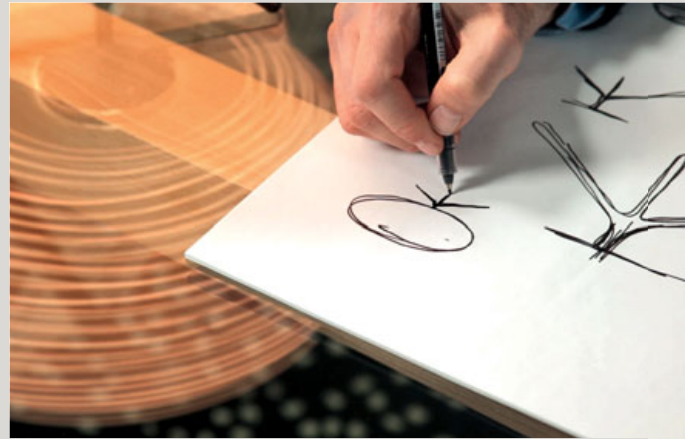

Le loro forme, diverse ma complementari, generano una famiglia completa e consentono di dare vita a molteplici composizioni, spaziando fra modelli a sospensione e da tavolo, parete, soffitto, con in più la possibilità di comporre fino a 9 sospensioni grazie al rosone multiplo.

The shapes, which are different yet complementary, generate a complete family and make it possible to put together multiple compositions, ranging from the suspension and table models, to the wall and ceiling versions, with the additional possibility of composing up to 9 suspensions thanks to the multiple canopy.

Versatile

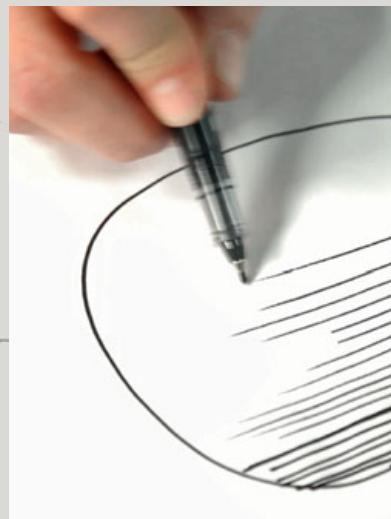
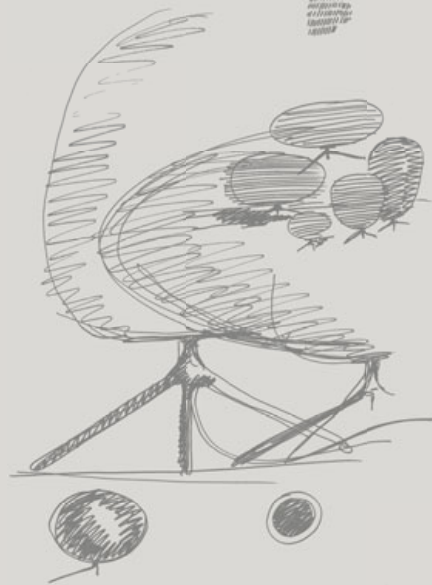
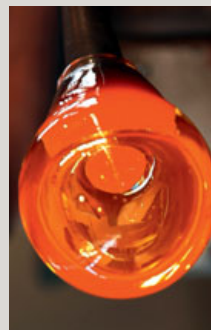

Rituals — Ludovica e Roberto Palomba, 2013

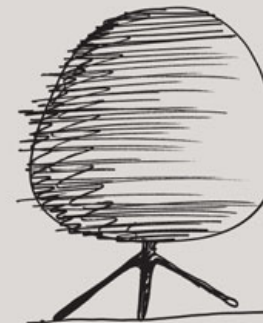

La loro superficie, percorsa da sottili incisioni che ricordano al tempo stesso l'increspatura della carta e la molatura del vetro, diffonde una luce soffusa, intima e carezzevole, ideale per accompagnare i molteplici riti dell'abitare contemporaneo.

The surface, covered with thin engravings that remind of both ruffled paper and glass grinding, diffuses an intimate and caressing light which is ideal for different habits of contemporary living.

Textes en français, Deutsche Texte, Textos en español → p. 343

Craftsmanship

Rituals

Ludovica e Roberto Palomba, 2013

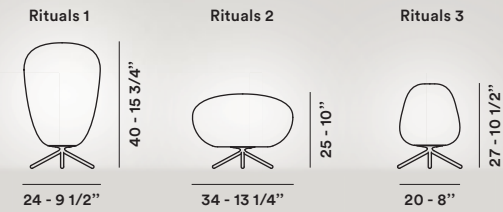

Vetro soffiato satinato inciso e metallo verniciato.
Blown engraved satin glass and varnished metal.

LED E27/E26
on/off version only

Rituals 1 - 2 - 3
220 / 240V: fluo 1x15W E27, halo 1x105W E27, halo 1x60W G9
120V: fluo 1x15W E26, halo 1x100W E26, halo 1x60W G9
Energy class A+, A, B, C

Dimmer incluso — *Dimmer included (G9)*

☐ ⚡ IP 20 — © (G9)

Bianco. *White.*

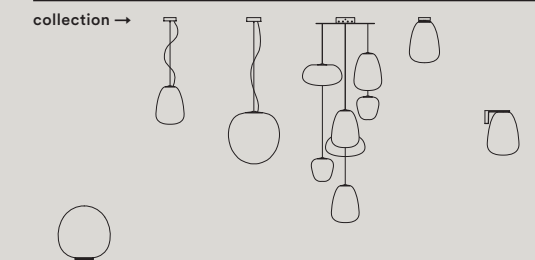

p. 060 p. 186 p. 188 p. 214 p. 256 p. 320



Rituals xl

Ludovica e Roberto Palomba, 2015

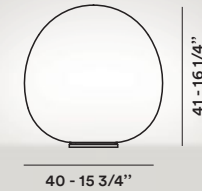

41 - 16 1/4\"/>

Vetro soffiato satinato inciso e metallo verniciato.
Blown engraved satin glass and varnished metal.

LED E27/E26
on/off version only

220 / 240V: halo 1x150W E27,
120V: halo 1x150W E26,
Energy class A+, A, B, C

Dimmer incluso — *Dimmer included*

IP 20

Bianco. *White.*



collection →

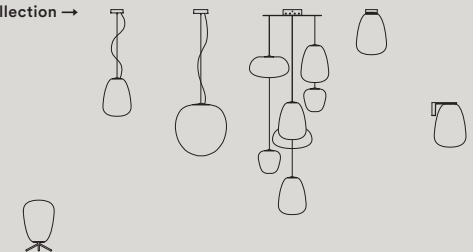

p. 058 p. 186 p. 188 p. 214 p. 256 p. 320



Tress

Marc Sadler, 2009

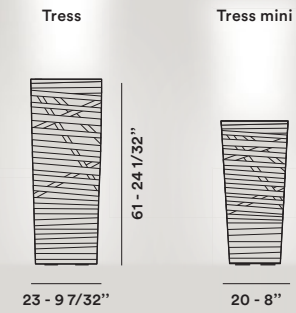

Materiale composito su base di fibra di vetro verniciato.
Varnished fibreglass based composite material.

Tress
220 / 240V: halo 1x100W E27
120V: halo 1x75W E26
Energy class C

Tress mini
220 / 240V: halo 1x75W GU10
120V: halo 1x75W GU10
Energy class C

Dimmer incluso — *Dimmer included*

☐ IP 20

Bianco, nero, rosso.
White, black, red.

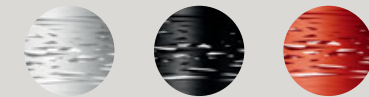

collection →

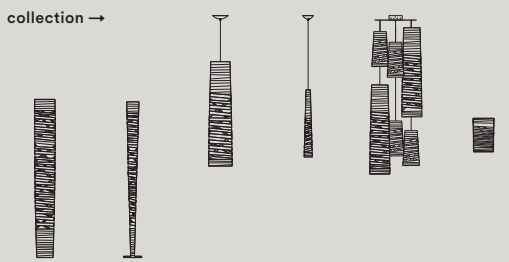

p. 110 p. 112 p. 196 p. 200 p. 214 p. 324

Twiggy xl

Marc Sadler, 2008

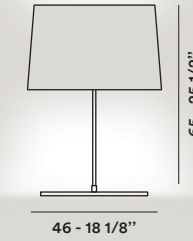

Materiale composito su base di fibra di vetro laccato, policarbonato e metallo verniciato.
Coated fibreglass based composite material, polycarbonate and varnished metal.

220 / 240V: halo 3x77W E27
120V: inc 3x100W E26
Energy class C

Dimmer incluso — *Dimmer included*

☐ IP 20

Bianco, nero.
White, black.



collection →

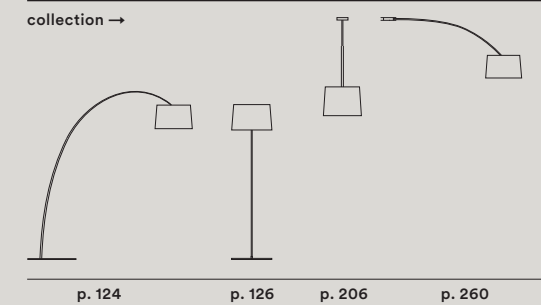

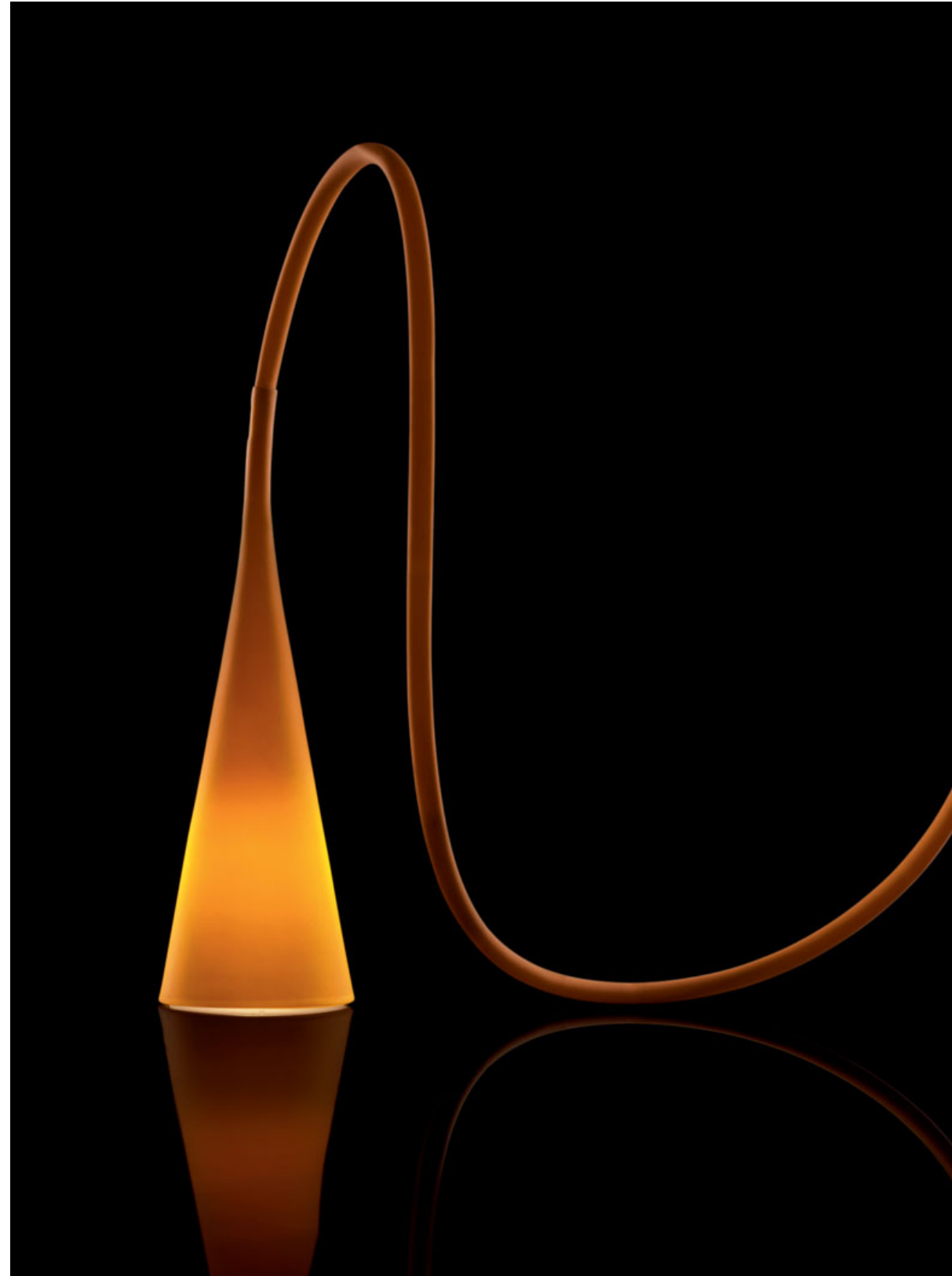

Uto

Lagranja Design, 2005

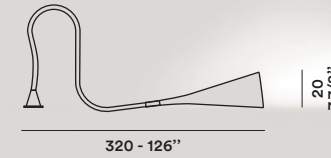

Elastomero termoplastico e policarbonato.
Thermoplastic elastomer and polycarbonate.

LED E27/E26

220 / 240V: fluo 1x15W E27
120V: fluo 1x13W E26
Energy class A+, A

☐ ⚡ IP 44

Suitable for damp location

Bianco, giallo, arancio.
White, yellow, orange.

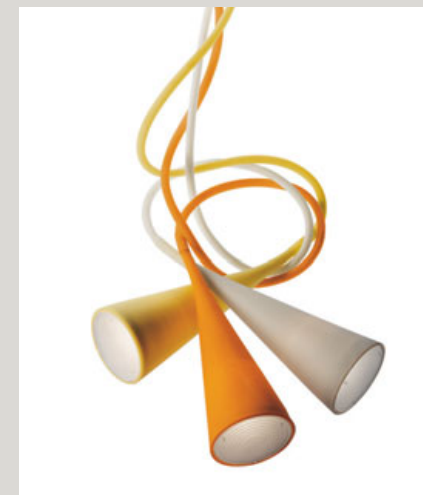

collection →

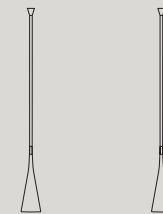

p. 208

p. 340



Yoko

Anderssen & Voll, 2013

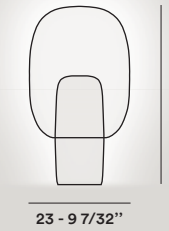

PMMA e policarbonato.
PMMA and polycarbonate.

LED E27/E26

220 / 240V: fluo 1x25W E27
120V: fluo 1x26W E26
Energy class A+, A

☐  IP 20

Verde, arancio, viola.
Green, orange, violet.



Terra — Floor

- 072 **Aplomb**
- 074 **Birdie**
- 076 **Caboche**
- 078 **Colibrì**
- 080 **Giga-Lite**
- 082 **Gregg**
- 084 **Havana**
- 090 **Lightwing**
- 092 **Magneto**
- 094 **Mite**
- 102 **Orbital**
- 108 **Stewie**
- 110 **Tress**
- 112 **Tress Stilo**
- 114 **Tuareg**
- 120 **Twiggy**
- 126 **Twiggy *lettura***

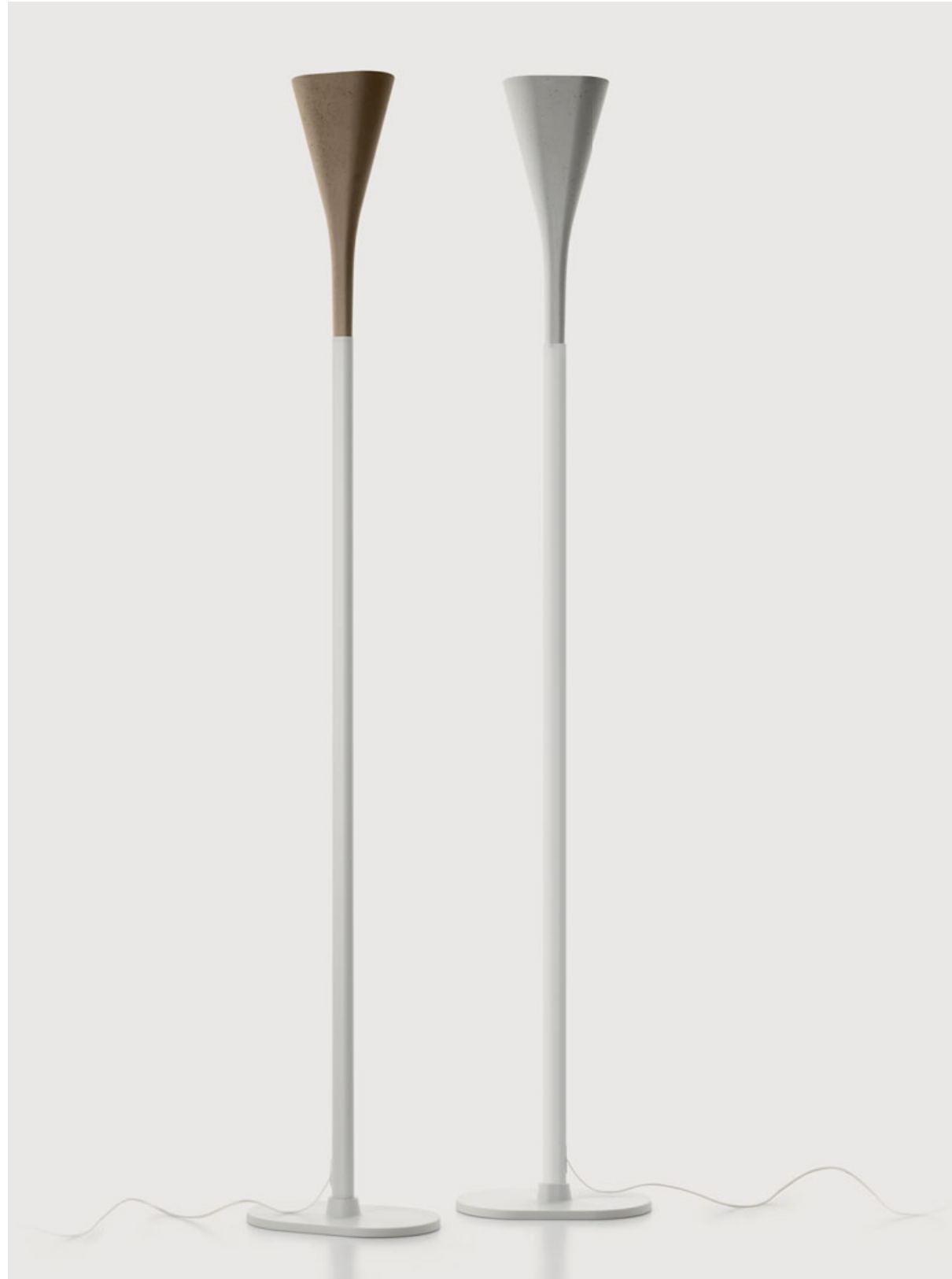

Aplomb

Paolo Lucidi e Luca Pevere, 2013

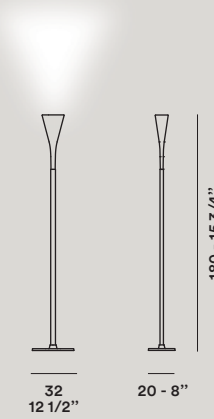

Cemento e metallo verniciato.
Concrete and varnished metal.

220 / 240V: halo 1x120W R7s
120V: halo 1x150W R7s
Energy class C

Dimmer incluso — Dimmer included

IP 20

Bianco, grigio cemento, marrone.
White, concrete grey, brown.



collection →

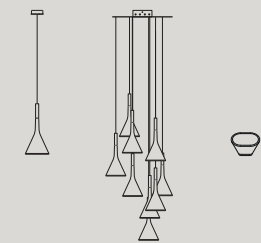

p. 138

p. 214

p. 264



Birdie

Ludovica e Roberto Palomba, 2011

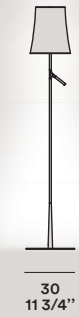

Policarbonato, acciaio e metallo verniciati.
Polycarbonate, varnished steel and metal.

LED E27/E26
on/off version only

220 / 240V: halo 1x150W E27,
fluo 1x25W E27
120V: halo 1x150W E26,
fluo 1x25W E26
Energy class A+, A, B, C

Touch-dimmer incluso
Touch-dimmer included



Bianco, grigio, arancio, amaranto.
White, grey, orange, amaranth.

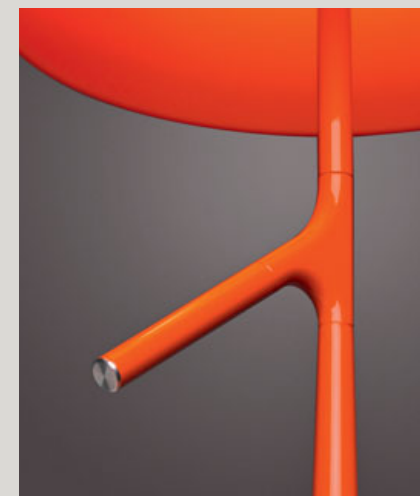

collection →

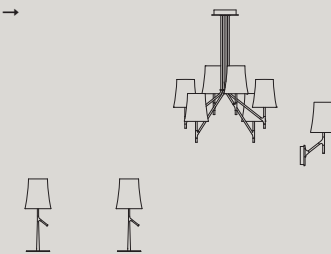

p. 026 p. 028 p. 236 p. 278

Caboche

Patricia Urquiola con Eliana Gerotto, 2005

grande



70
29 1/2"

178 - 70"

media



50
19 3/4"

154 - 60 3/5"

Polimetilmetacrilato, vetro soffiato e metallo verniciato.
Polymethylmethacrylate, blown glass and varnished metal.

grande
220 / 240V: halo 1x230W R7s
120V: halo 1x200W RSC
Energy class C

media
220 / 240V: halo 1x160W R7s
halo 1x150W RSC
Energy class C

Dimmer incluso — *Dimmer included*

IP 20

Trasparente, giallo oro.
Transparent, gold yellow.



collection →

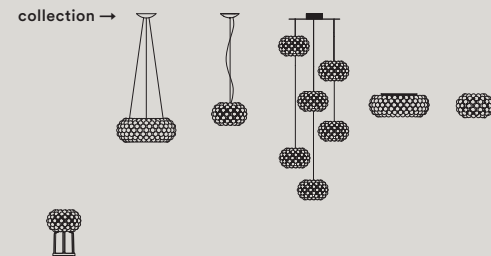

p. 030

p. 152

p. 154

p. 214

p. 240

p. 284



Colibrì

Odoardo Fioravanti, 2011

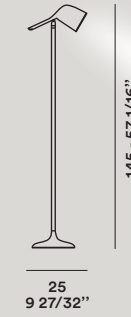

Policarbonato, alluminio e metallo verniciati.
Polycarbonate, varnished aluminium and metal.

220 / 240V: halo 1x75W GU10
120V: halo 1x75W GU10
Energy class C

Dimmer incluso — *Dimmer included*

IP 20

Bianco, verde.
White, green.

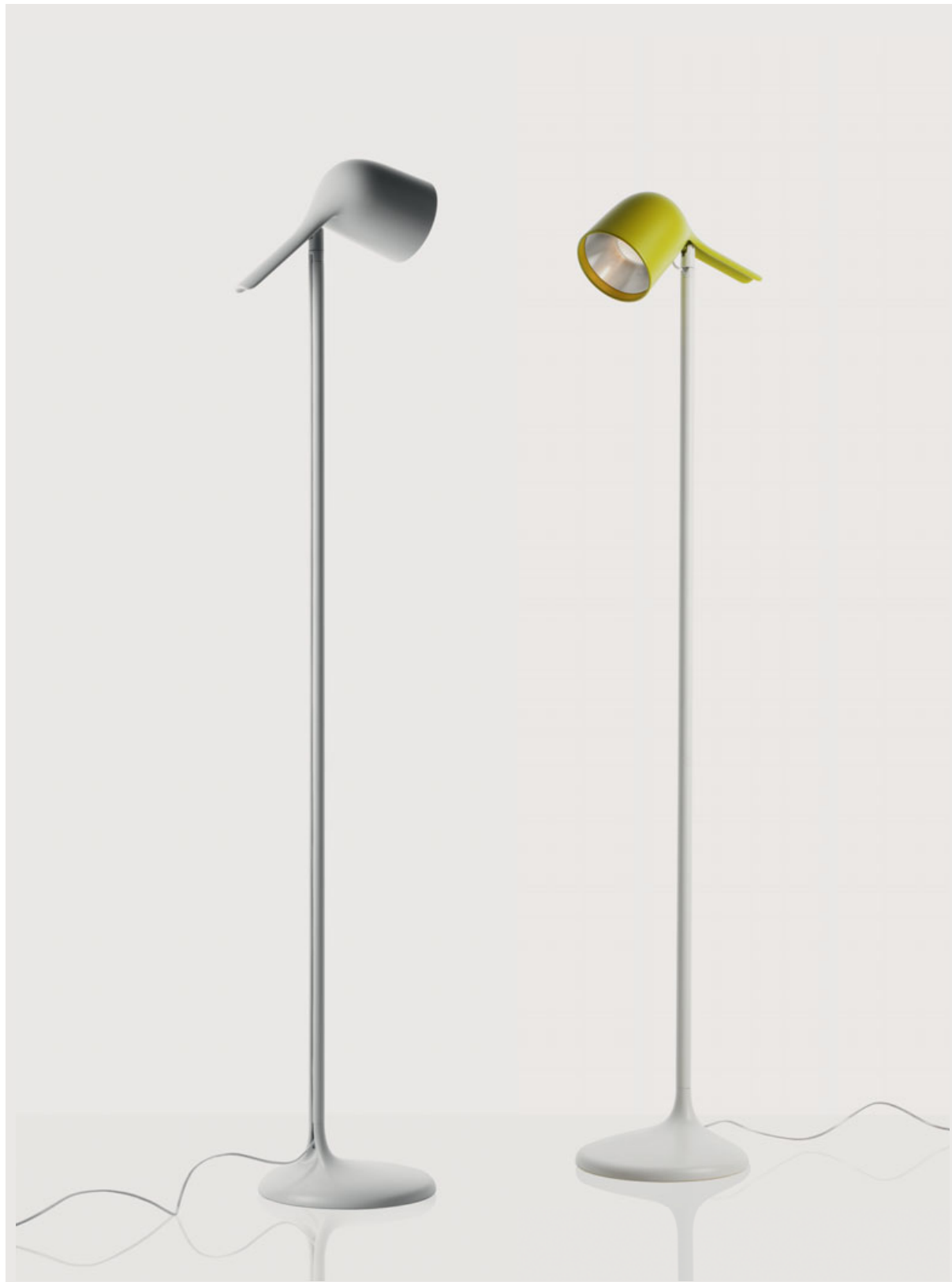

Giga-Lite

Marc Sadler, 2004

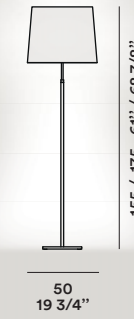

Tessuto di vetro, fibra di carbonio e acciaio inox. Stelo estensibile.
Fiberglass fabric, carbonium thread and stainless steel. Extendable.

220 / 240V: halo 3×100W E27
120V: inc 3×150W E26
Energy class C

Dimmer incluso — *Dimmer included*

IP 20

Nero. *Black.*



collection →

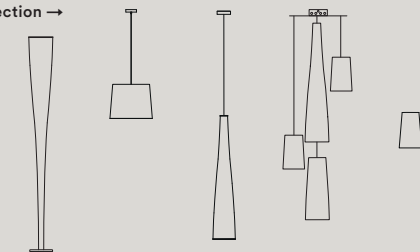

p. 100

p. 162

p. 194

p. 214

p. 310



Gregg

Ludovica e Roberto Palomba, 2010

grande

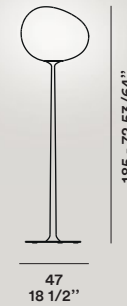

media

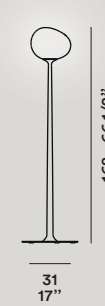

Vetro soffiato acidato, poliuretano verniciato e metallo.
Blown acid-etched glass, varnished polyurethane and metal.

220 / 240V: halo 1x205W E27
120V: halo 1x150W E26
Energy class C

Dimmer incluso — *Dimmer included*

IP 20

Bianco. *White.*



collection →

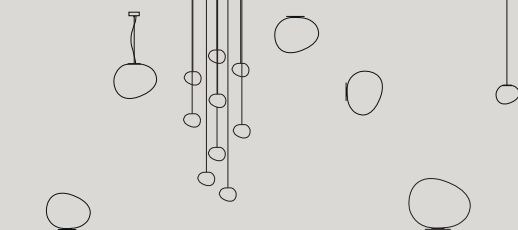

p. 036 p. 164 p. 214 p. 250 p. 304 p. 332 p. 330



Lampada da terra, sospensione, parete ed esterno — *Floor, suspension, wall and outdoor lamp*

Havana

Joseph Forakis, 1993

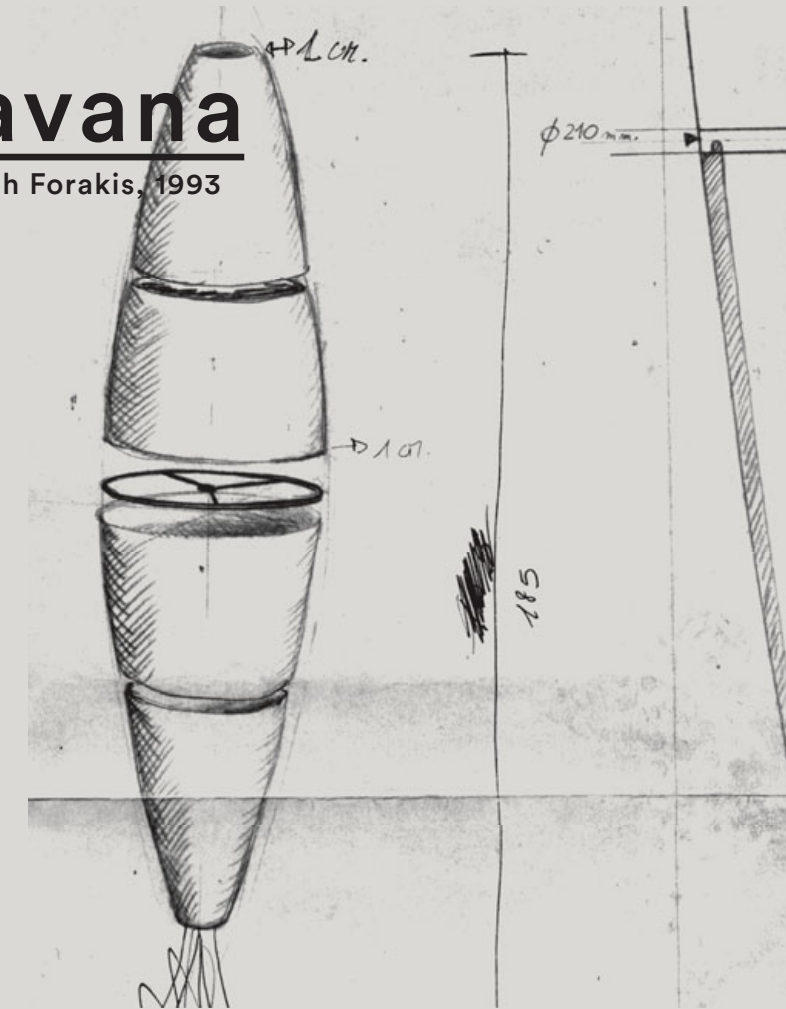

Havana, lampada rivoluzionaria. Vi può capitare di incontrarla dovunque: in un elegante salotto, un locale di tendenza o sul bordo di una piscina. Affusolata come un sigaro, Havana ha uno stile senza età e si trova perfettamente a proprio agio in qualsiasi ambiente, diffondendo attorno a sé una luminosità calda, soffusa e solare.

Havana, a revolutionary lamp. You could happen to see it anywhere: in a stylish living room, trendy eatery or the side of a swimming pool. Tapered like a cigar, Havana has a timeless style which fits perfectly in any environment, diffusing a warm, suffused and sunny light all around.

Personality

Havana — Jozeph Forakis, 1993

È realizzata in polietilene bianco: un materiale leggero, durevole, resistente e riciclabile. È disponibile in versione da terra, da parete e da sospensione, per interni o esterni ed è ambientabile da sola oppure in affascinanti composizioni multiple.

It is made of white polyethylene: a light-weight, durable, hard-wearing and recyclable material. Havana is available in floor, wall and suspension version, for indoor and outdoor use proposed as a stand-alone lamp or in beguiling multiple compositions.

Everywhere

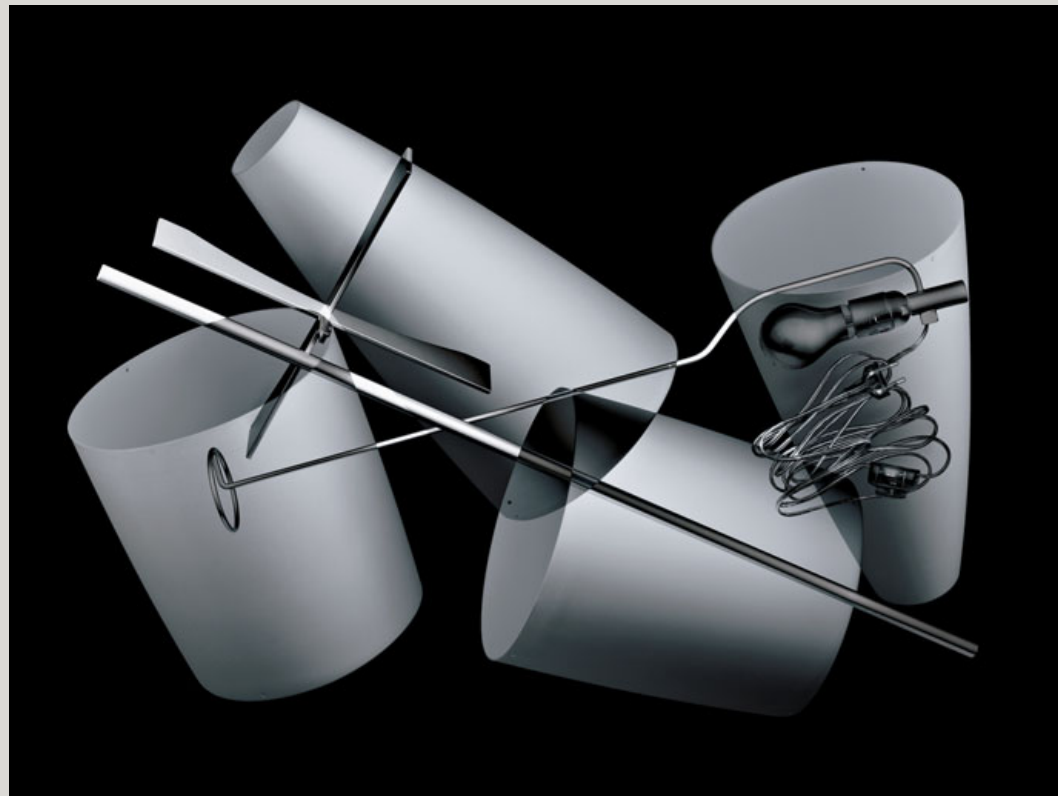

Prototipo — Prototype

Accolta nella collezione permanente del Museum of Modern Art di New York, è uno dei più grandi successi Foscarini: un esempio di come anche il design più raffinato, possa permettersi un piacevole sapore di accessibilità, leggerezza e ironia.

Havana has been honoured to be part of the permanent collection of the New York Museum of Modern Art and it is one of Foscarini's greatest successes: an example of how even the most sophisticated design can afford an enjoyable flair of accessibility, light-weight and irony.

Textes en français, Deutsche Texte, Textos en español → p. 343

Ironic



Havana

Jozeph Forakis, 1993

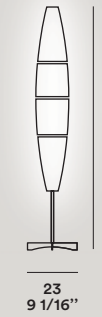

Polietilene stampato ad iniezione e metallo verniciato.
Injection moulded polyethylene and varnished metal.

LED E27/E26
 on/off version only

220 / 240V: halo 1x116W E27,
 fluo 1x25W E27
 120V: inc 1x150W E26,
 fluo 1x26W E26
Energy class A+, A, B, C

220 / 240V: Dimmer version available



Diffusore: bianco.
Diffusor: white.
 Montatura: alluminio, cromo.
Frame: aluminium, chrome.

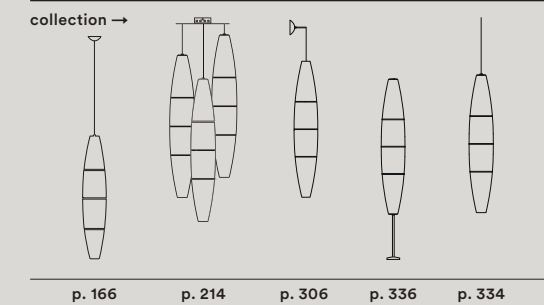
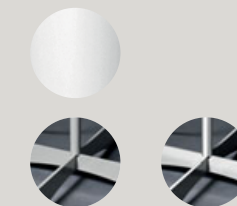

Lightwing

Jean Marie Massaud, 2013

LED

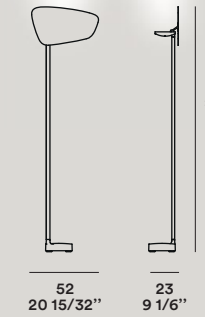

Alluminio verniciato e lega di zinco.
Varnished aluminum and zinc alloy.

LED 34W 3000°K 3157 lm included
Energy class A+

Dimmer incluso — *Dimmer included*

⊕ ⚡ IP 20

Bianco, nero.
White, black.



Magneto

Giulio Iacchetti, 2011



Acciaio verniciato, ABS e supermagnete
in terre rare.
*Varnished steel, ABS and super magnet
made of "rare earth".*

LED 5W 2700° K 475 lm included
Energy class A+

IP 20

Bianco, Nero.
White, black.

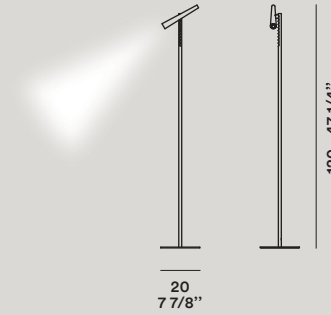

collection →



p. 048



Lampada da terra — *Floor lamp*

Mite

Marc Sadler, 2000

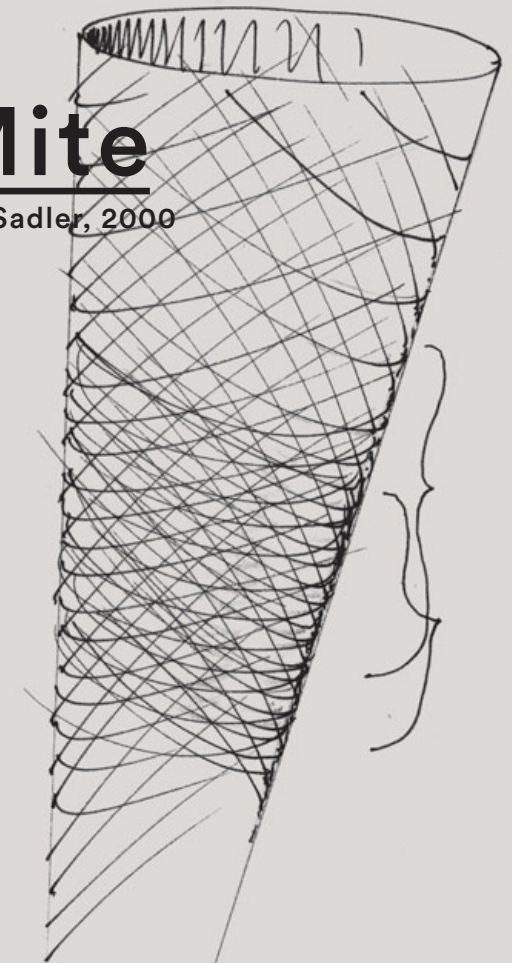

Mite, personalità mitica. Slanciata, elegante, importante, inconfondibile da accesa come da spenta. Una forma sinuosa, vestita con una trama di vetro e filo di carbonio o di Kevlar®, le stesse fibre tecnologiche utilizzate per creare barche a vela e mazze da golf.

Mite, mythical personality. Sleek, sophisticated and important, unmistakable both on and off. A sinuous shape, clad with fiber glass fabric and carbon or Kevlar® yarn, the same high-tech fibres used to build sailing boats and golf clubs.

Research



Mite — Marc Sadler, 2000



Un'innovazione assoluta che ha valso a Mite, insieme alla versione a sospensione Tite, il premio Compasso d'Oro ADI, fra i più prestigiosi nel mondo del design.

This absolute innovation earned Mite, together with the Tite suspension version, the ADI Compasso d'Oro, one of the most prestigious design awards in the world.

Innovation



Compasso D'Oro 2001



Mite — Marc Sadler, 2000

Una lampada che è diventata un'icona nel panorama dell'illuminazione e che ora, nella nuova versione a LED, esprime una luminosità ancora più affascinante, con inoltre il vantaggio di una tecnologia amica dell'ambiente.

This lamp has become an icon on the lighting scene and now, in this new LED version, it expresses an even more beguiling luminosity, with the added benefit of an environmentally-friendly technology.

Textes en français, Deutsche Texte, Textos en español → p. 343

Icon

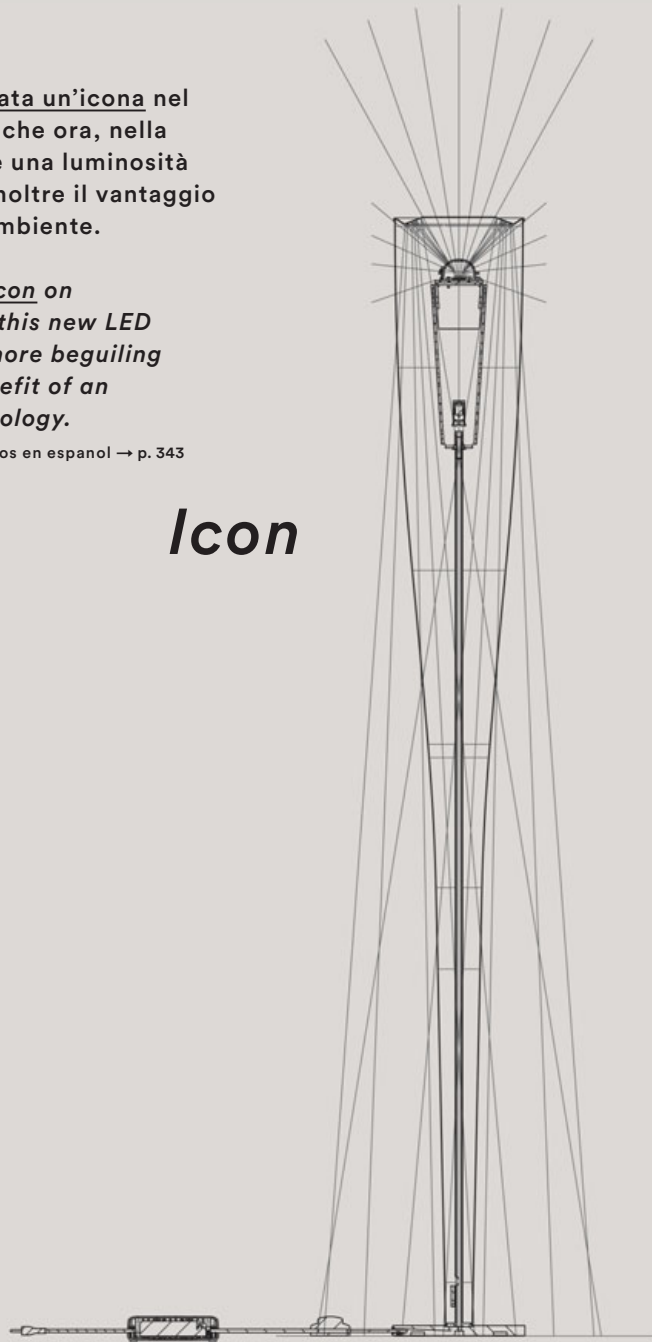

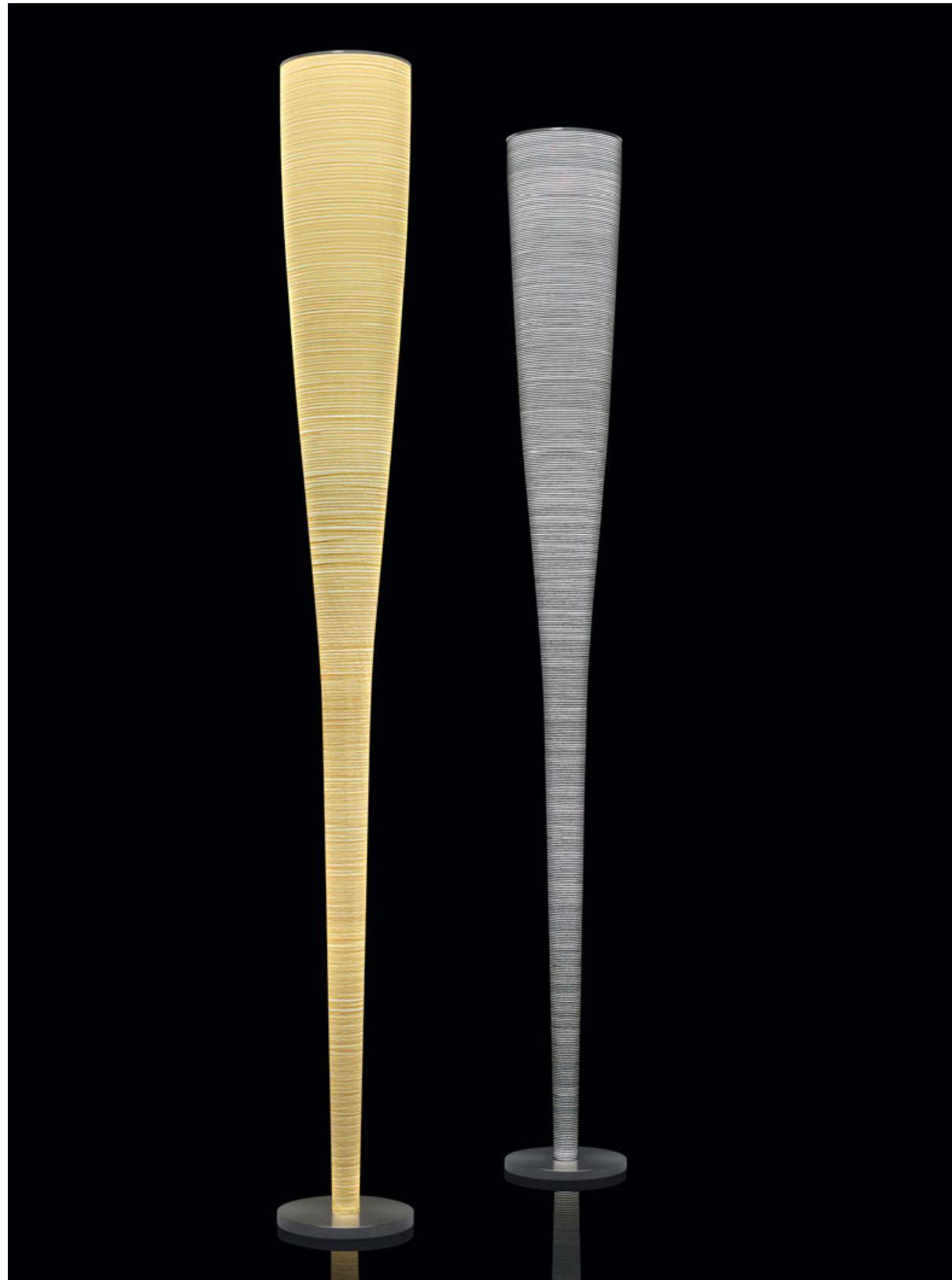

Mite

Marc Sadler, 2000



Tessuto di vetro con fibra di carbonio o Kevlar®, metallo nichelato, acciaio e alluminio (LED).

Fiber glass fabric with Kevlar® or carbonium thread, nickel-plated steel and aluminium (LED).

Kevlar® is a Dupont registered trademark.

LED 32W 3000°K 2500 lm included
Energy class A

220 / 240V: halo 1x150W E27
120V: inc 1x150W E26
Energy class C

Dimmer incluso — *Dimmer included*

☐ ⚡ IP 20 — Ⓢ (halo)

Giallo, nero.
Yellow, black.



collection →

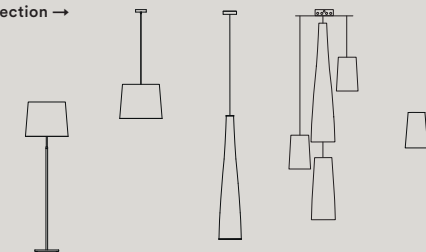

p. 080

p. 162

p. 194

p. 214

p. 310

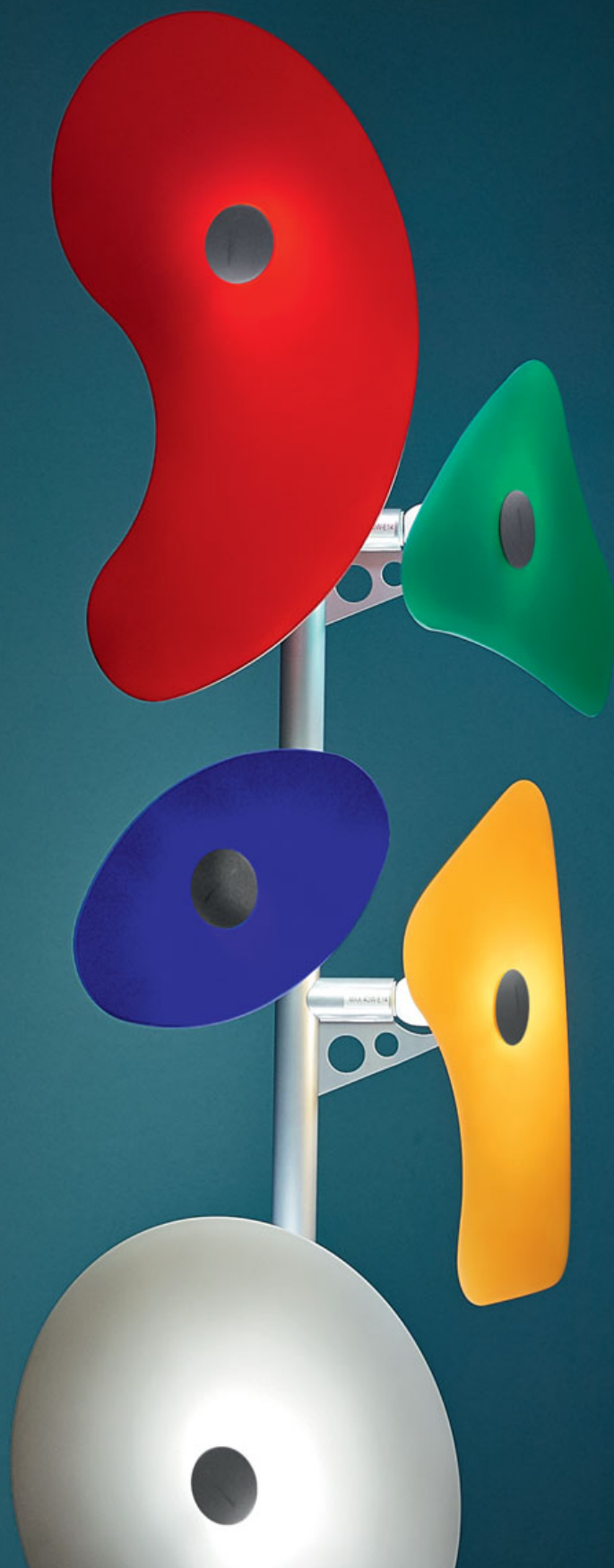

Lampada da terra — Floor lamp

Orbital

Ferruccio Laviani, 1992

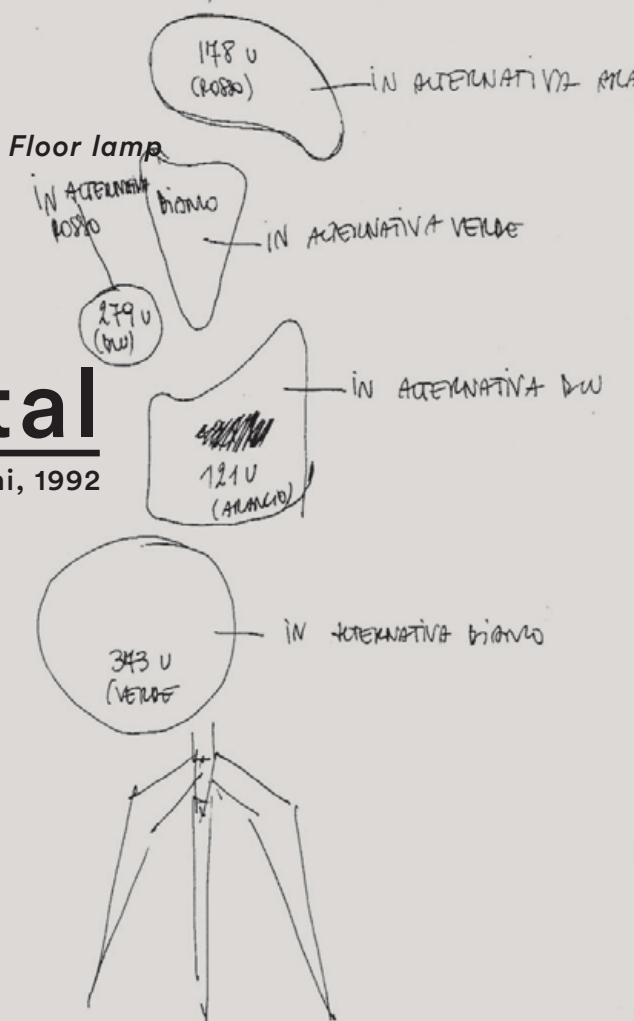

Orbital, scultura domestica. È una lampada o un'installazione artistica? Lanciata nel 1991, considerata fino dal suo apparire come un oggetto unico nell'universo del design, raffigurata addirittura in un francobollo, *Orbital* è forse entrambe le cose.

Orbital, domestic sculpture. Is it a lamp or artistic installation? Launched in 1991, considered from the onset to be a unique object in the world of design, depicted even in a postage stamp, *Orbital* is perhaps both these things.

Sculpture



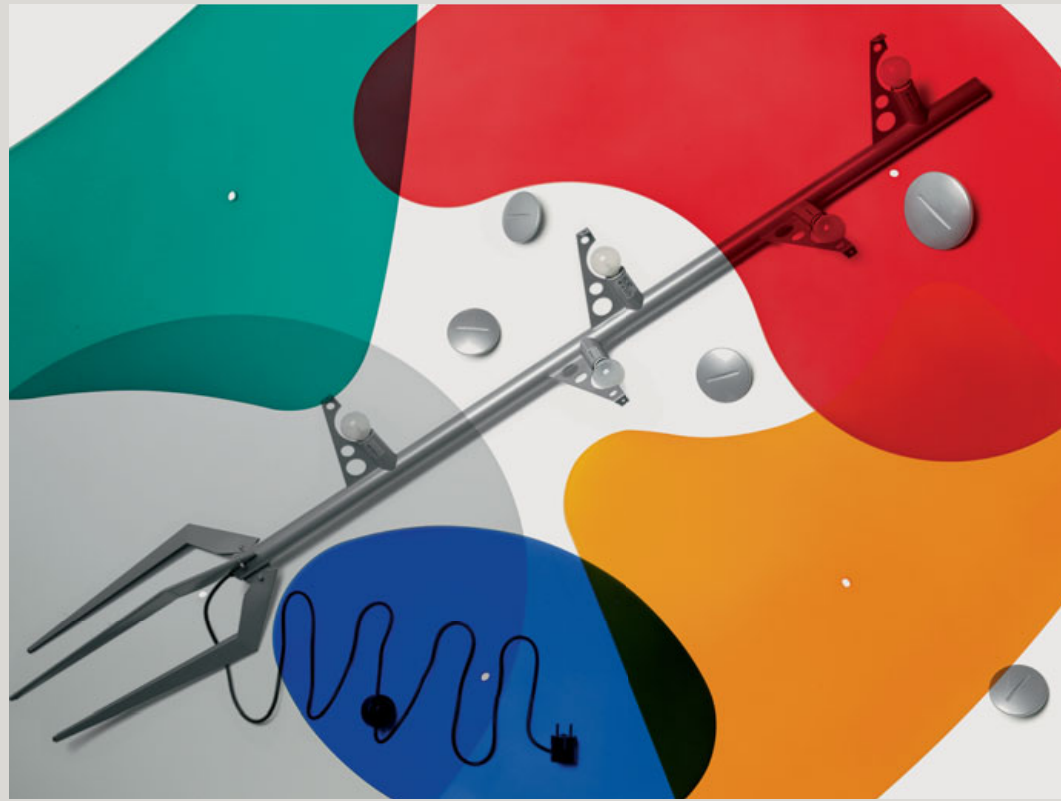

Una composizione di sagome in vetro serigrafato, ispirate alle forme delle galassie, su una struttura di metallo laccato, dal sapore industriale. Bianca o multicolore, Orbital diffonde un segnale visivo inconfondibile nello spazio attorno a sè, con una luminosità, oltre che con una forma estetica, assolutamente speciale.

Entailing a composition of silk-screen printed glass shapes, inspired by the galaxies, on a lacquered metal structure oozing industrial appeal. White or multi-coloured, Orbital diffuses an unmistakable visual signal into its surroundings, with a brightness, and aesthetic form, that are truly spectacular.

Multicolor



Orbital — Ferruccio Laviani, 1992

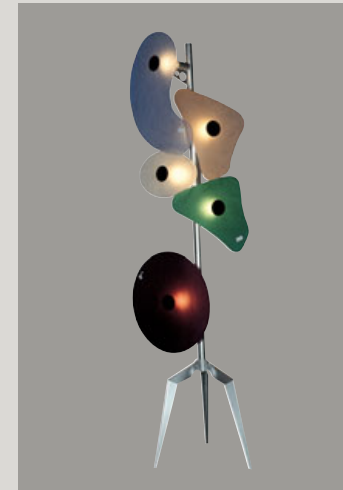

Prototipo — Prototype

Le lampadine a vista sono infatti un elemento integrante del design di quest'opera, espressione di una creatività e cultura del progetto tipicamente italiana.

The visible light bulbs in fact form an integral part of the design of this object, the expression of a typically Italian creativity and design culture.

Textes en français, Deutsche Texte, Textos en español → p. 343

Creativity

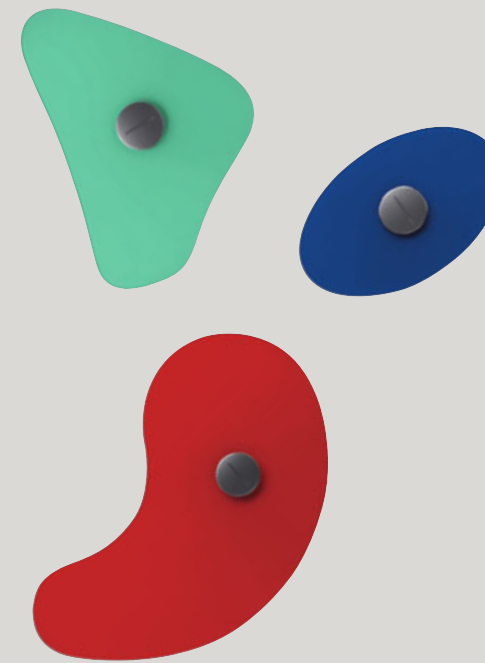

Orbital

Ferruccio Laviani, 1992

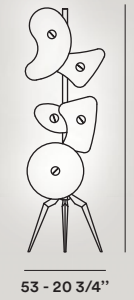

Vetro serigrafato e metallo verniciato.
Silkscreen-printed glass and varnished metal.

220 / 240V: halo 5x30W E14
120V: inc 5x40W E12
Energy class C

⊕ ⚡ IP 20

Bianco, colorato.
White, colored.



collection →



Stewie

Luca Nichetto, 2012

Polietilene espanso rivestito in tessuto e metallo verniciato.
Polyethylene foam coupled with fabric and lacquered metal.

220 / 240V - 120V: halo 1x40W 2GX13
Energy class A+, A

 IP 20

Avorio, rosso.
Ivory, red.

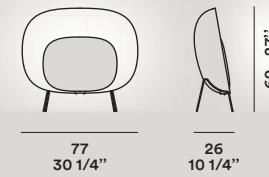



Tress

Marc Sadler, 2008



Tress grande

Tress media



25
9 27/32"

24
9 7/16"

195 - 76 25/32"

110 - 43 5/16"

Materiale composito su base di fibra di vetro laccato, metallo verniciato e alluminio.
Compound material on lacquered glass fibre base, varnished metal and aluminium.

Tress grande
220 / 240V: LED 56W 3000° K 3721 lm included
120V: LED 46W 3000° K 3193 lm included
Energy class A+

220 / 240V: halo 1x100W E27 + halo 1x230W R7s
120V: halo 1x75W E26 + halo 1x300W RSC
Energy class C

Dimmer incluso, doppia accensione
— *Dimmer included, double switch*

Tress media
220 / 240V: halo 1x100W E27
120V: halo 1x75W E26
Energy class C

Dimmer incluso — *Dimmer included*

☐ ⚡ IP 20 — © (halo grande)

Bianco, nero, rosso. *White, black, red.*

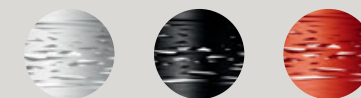

collection →

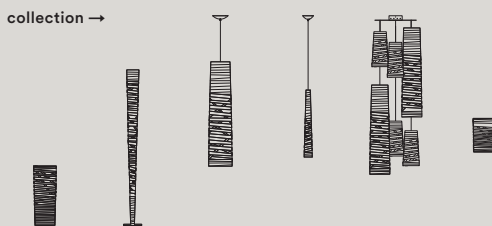

p. 062 p. 112 p. 196-198 p. 200 p. 214 p. 324

Tress Stilo

Marc Sadler, 2011



Materiale composito su base di fibra di vetro laccato, metallo verniciato e acciaio
Compound material on lacquered glass fibre base, varnished metal and steel.

220 / 240V: halo 1x100W E27
 120V: halo 1x75W E26
Energy class C

Dimmer incluso — *Dimmer included*

IP 20

Bianco, nero, rosso.
White, black, red.

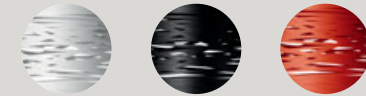

collection →

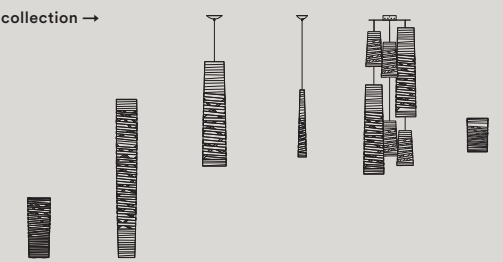

p. 062 p. 110 p. 196-198 p. 200 p. 214 p. 324



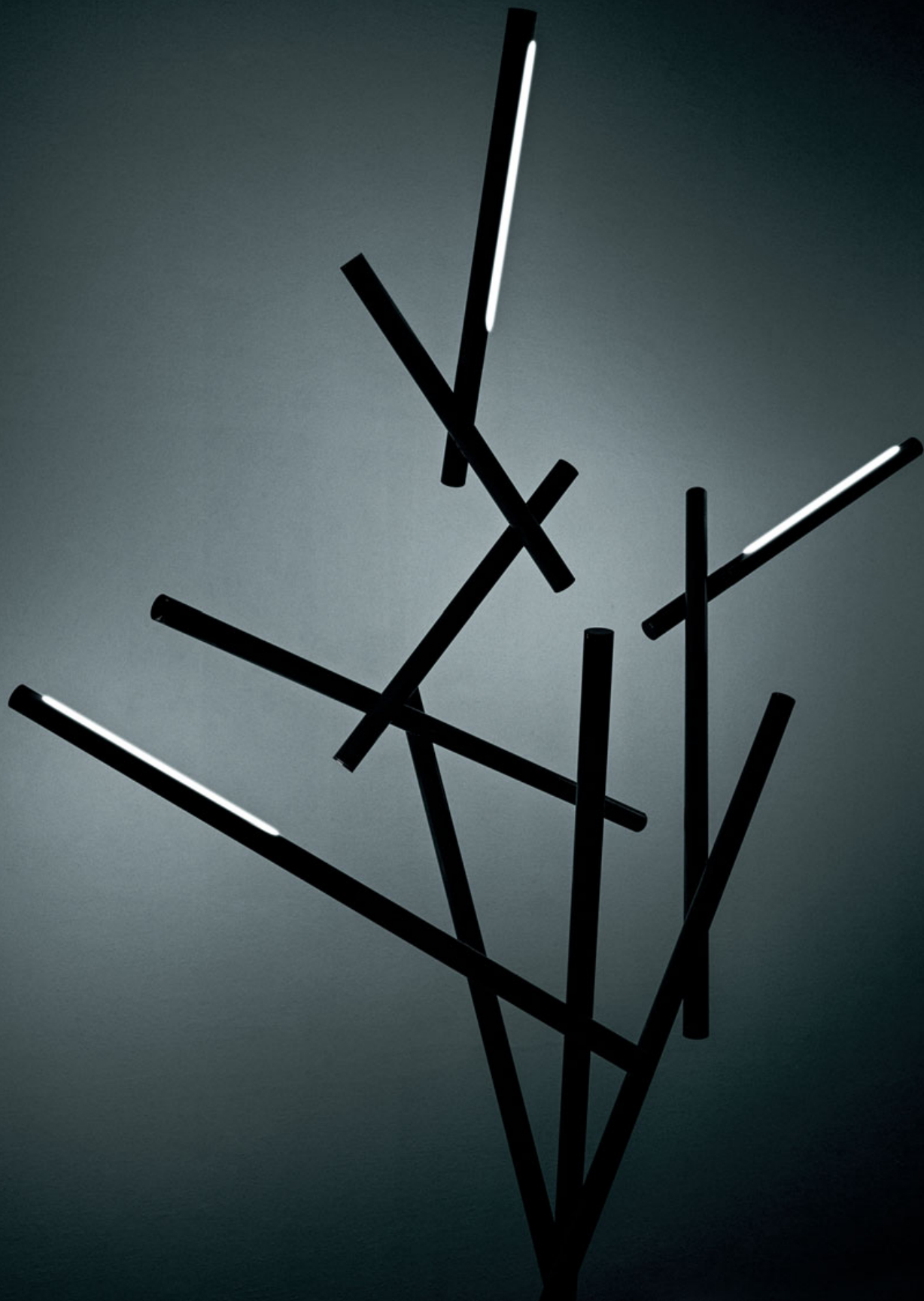

Lampada da terra — Floor lamp

Tuareg

Ferruccio Laviani, 2013

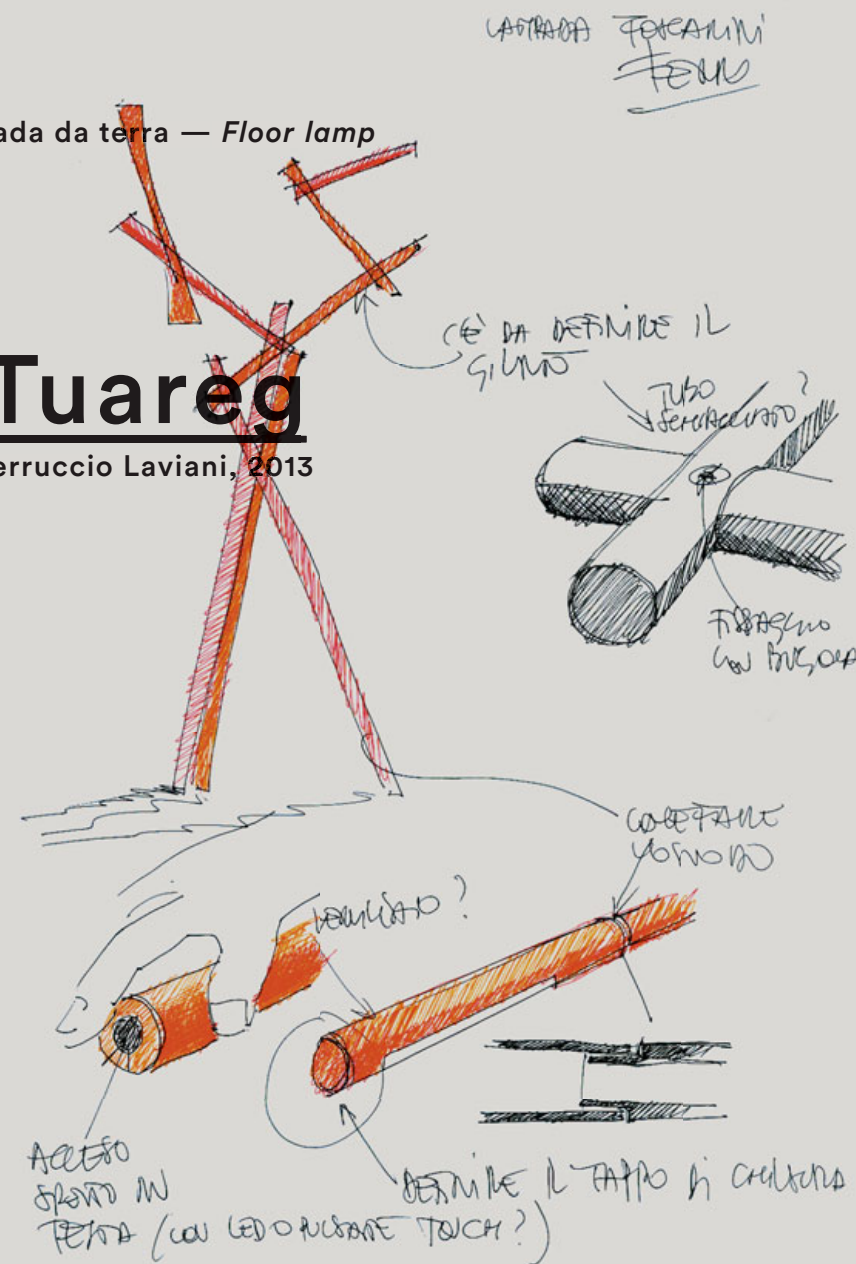

Tuareg, nuova forma di illuminazione. Una lampada da terra che prende ispirazione dalle primitive strutture realizzate nelle culture tribali, legando insieme rami o canne di bambù, per dare vita a un'architettura sorprendente, innovativa.

Tuareg, a new form of lighting. A floor lamp that draws inspiration from the primitive structures built by tribal cultures tying together branches or bamboo canes, that gives life to a surprising, innovative architecture.

Ancestral

Tuareg — Ferruccio Laviani, 2013

Solo apparentemente caotica ma in realtà estremamente funzionale. Tuareg è formata da tubi in alluminio che compongono una geometria tridimensionale, con luci a LED che si possono accendere con un semplice gesto ed orientare a 360° in maniera indipendente, per creare infinite possibilità di illuminazione.

Apparently chaotic but in reality extremely functional, Tuareg is made of aluminium tubes which create a 3D geometric shape, with LED lights that can be turned on with one simple movement and independently adjusted 360°, to create endless lighting possibilities.



Geometric

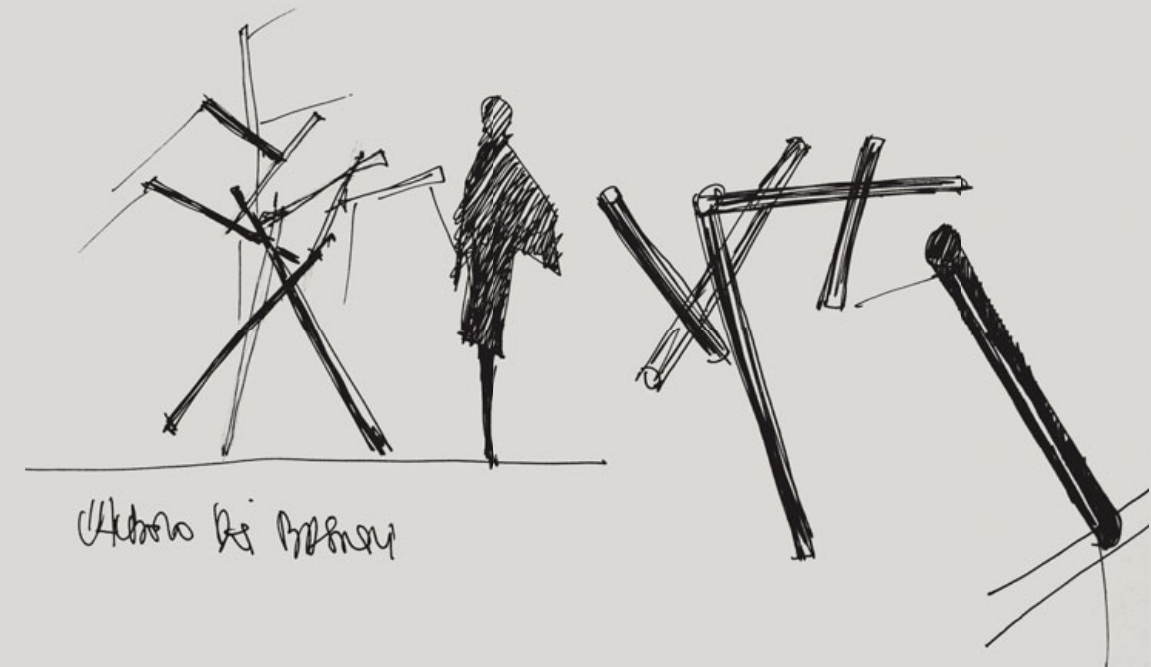

Non solo la forma e la luce, ma anche il colore ha un ruolo importante in Tuareg: un elegante abito nero adatto a ogni occasione, oppure un brillante arancione che ricorda situazioni industriali, per ambienti non convenzionali.

Not just the shape and the light are important for Tuareg, but also the colour: an elegant black suit is perfect for any occasion, or a bright orange overalls to recall industrial environments for the less conventional settings.

Textes en français, Deutsche Texte, Textos en español → p. 343

Graphic

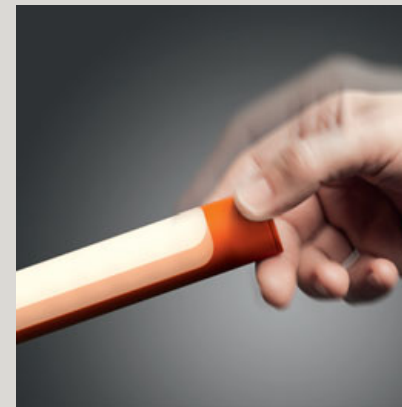

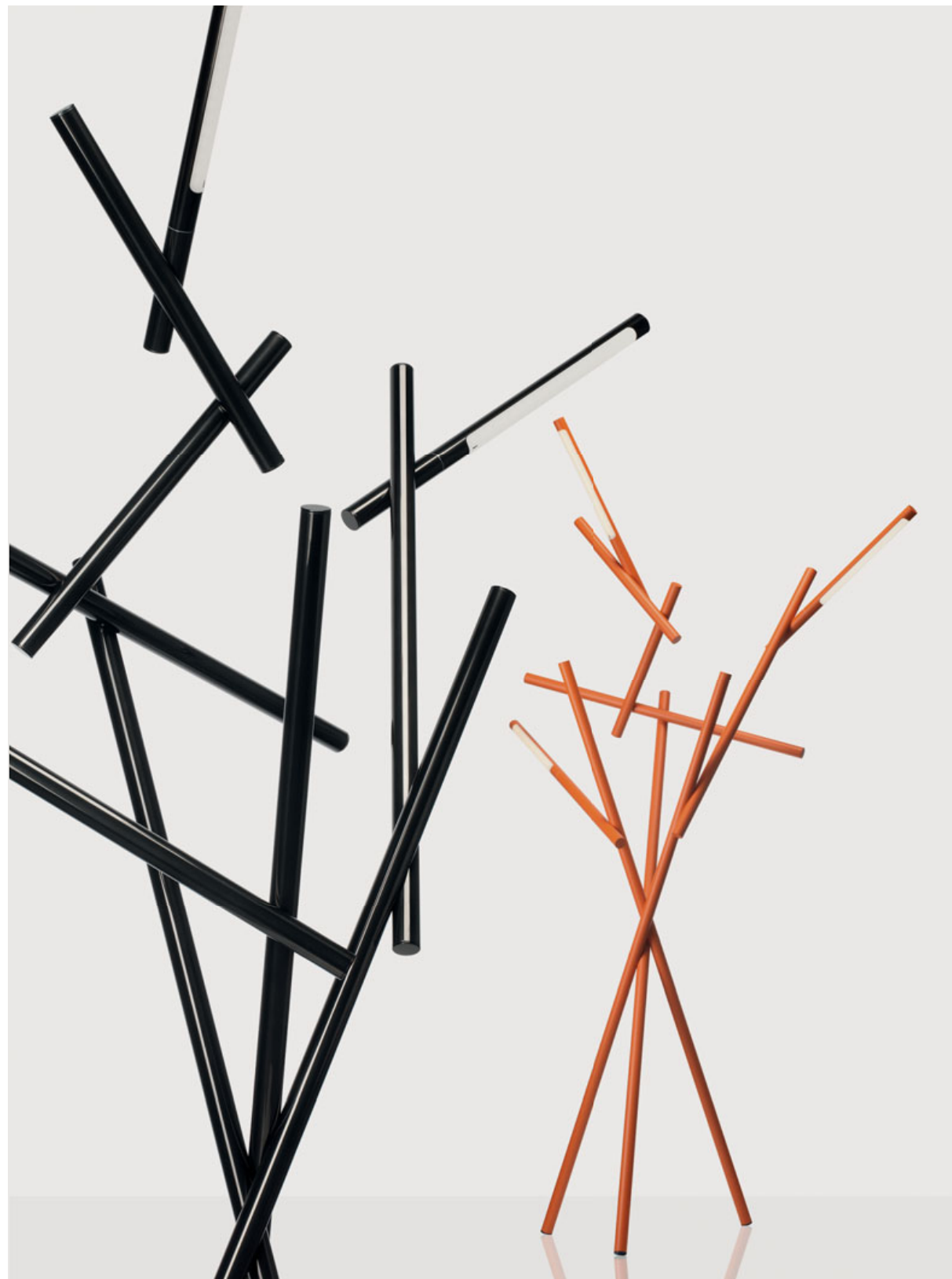

Tuareg

Ferruccio Laviani, 2013

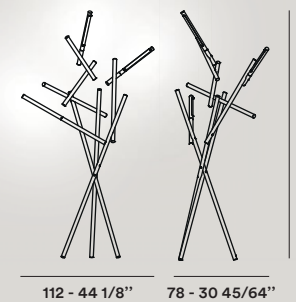

Alluminio verniciato e policarbonato.
Varnished aluminium and polycarbonate.

220 / 240V: LED 54W 3000°K 4050 lm included
120V: LED 50,4W 3000°K 3750 lm included
Energy class A+

Accensioni separate e luci orientabili —
Separate switches and orientable lights
Touch dimmer incluso — *Touch dimmer*
included

☐ ⚡ IP 20

Arancio, cromo nero.
Orange, black chrome.





Lampada da terra, tavolo, sospensione e soffitto — *Floor, table, suspension and ceiling lamp*

Twigg

Marc Sadler, 2006

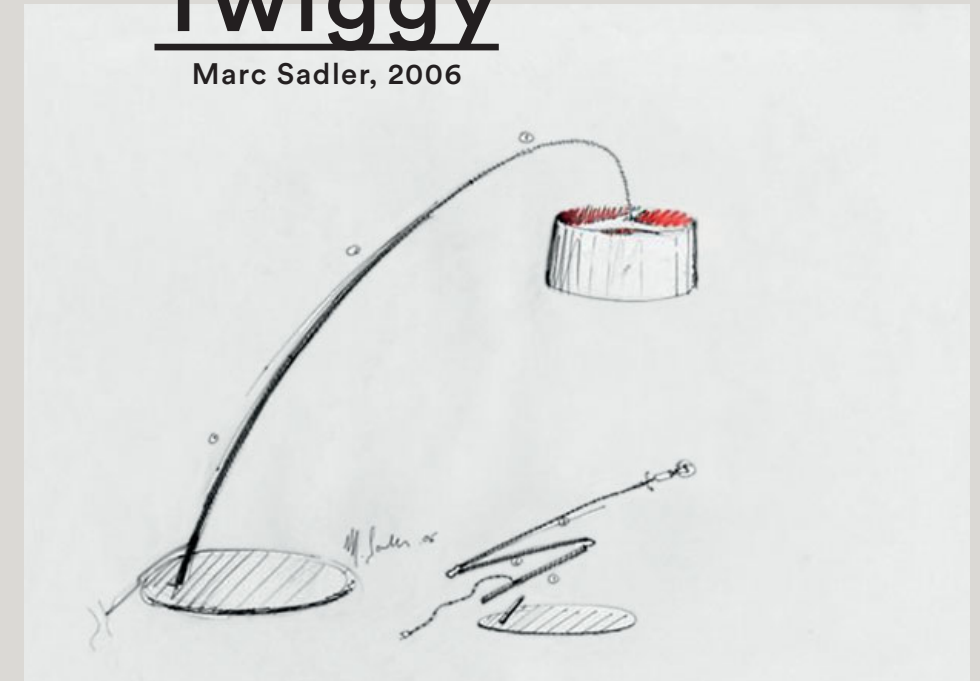

Twigg, semplicemente geniale.

Immaginate una linea sottilissima, flessibile ed arcuata che, come per magia, sostiene nell'aria un ampio diffusore che illumina contemporaneamente verso il basso con una luce diretta, verso l'alto con una luce soffusa. Fatto? Bene, avete appena immaginato Twigg, una lampada che unisce la ricerca di una semplicità assoluta, con le possibilità offerte dai materiali contemporanei.

Twigg, simply genius. Imagine an ultra-thin, flexible and arched line, which by magic suspends a large diffuser in mid-air, concurrently casting direct light downwards and suffused light upwards. Done? Good, you have just imagined Twigg, a lamp that teams the pursuit of absolute simplicity with the possibilities given by contemporary materials.

Simple

Twiggy — Marc Sadler, 2006

Come una canna da pesca, Twiggy si piega armoniosamente ed inoltre è regolabile in altezza per soddisfare ogni esigenza di ambientazione.

Like a fishing rod, Twiggy bends harmoniously and furthermore it is height-adjustable to accommodate all setting requirements.

Clever



A fianco di un divano o una chaise longue, sopra un tavolo o una scrivania, da sola come un segno inconfondibile nello spazio, oppure in scenografiche composizioni: sempre con un'eccezionale personalità e flessibilità.

Beside a sofa or a reclining armchair, on top of a table or a desk, either alone as an unmistakable feature of the setting, or in scenographic compositions: it always has an exceptional personality and flexibility.

Textes en français, Deutsche Texte, Textos en español → p. 343

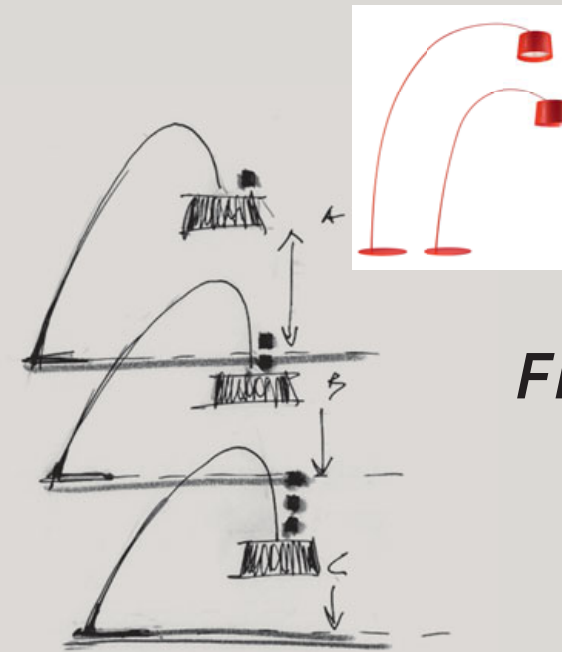

Flexible



Twiggy

Marc Sadler, 2006

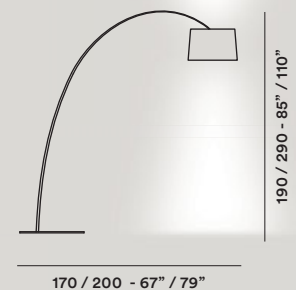

Materiale composito su base di fibra di vetro laccato, PMMA, policarbonato, metallo verniciato e alluminio (LED).
Varnished fibreglass based composite material, PMMA, polycarbonate, varnished metal and aluminium (LED).

LED 33W 3000° K 2920 lm included
Energy class A+

Dimmer incluso — *Dimmer included*

220 / 240V: halo 3x77W E27
 120V: halo 3x100W E26
Energy class C

Dimmer incluso — *Dimmer included*



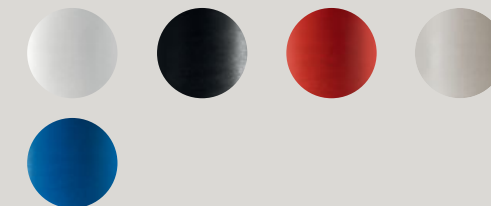

 IP 20 —  (halo)

Bianco, nero, cremisi, greige, indaco.
White, black, crimson, greige, indigo.

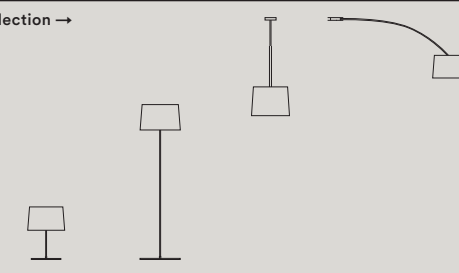

collection →



p. 064

p. 126

p. 206

p. 260

Twiggy lettura

Marc Sadler, 2008



Materiale composito su base di fibra di vetro laccato, PMMA, policarbonato e metallo verniciato.
Coated fibreglass based composite material, PMMA, polycarbonate and varnished metal.

220 / 240V: halo 3x77W E27
120V: inca 3x100W E26
Energy class C

Dimmer incluso — *Dimmer included*

☐ IP 20

Bianco, nero.
White, black.



collection →

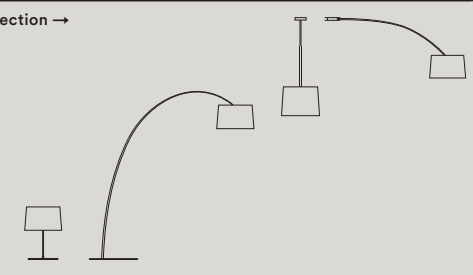

p. 064

p. 124

p. 206

p. 260



Sospensione — *Suspension*

- | | | | |
|-----------|--------------------|-----------|--------------------|
| 130 | Allegro | 178 | O-Space |
| 136 | Allegretto | 180 | Planet |
| 138 | Aplomb | 182 - 185 | Plass |
| 140 | Behive | 186 | Rituals |
| 142 | Big Bang | 189 | Rituals xl |
| 148 - 155 | Caboche | 190 | Spokes |
| 156 - 161 | Chouchin | 192 | Supernova |
| 162 | Giga-Lite | 194 | Tite |
| 164 | Gregg | 196 - 199 | Tress |
| 166 | Havana | 200 | Tress Stilo |
| 168 | Jamaica | 202 | Troag |
| 170 | Le Soleil | 204 | Tropico |
| 172 | Lightweight | 206 | Twiggy |
| 174 | Maki | 208 | Uto |
| 176 | New Buds | 210 | Wave |



Lampada da sospensione — *Suspension lamp*

Allegro

Atelier Oi, 2007

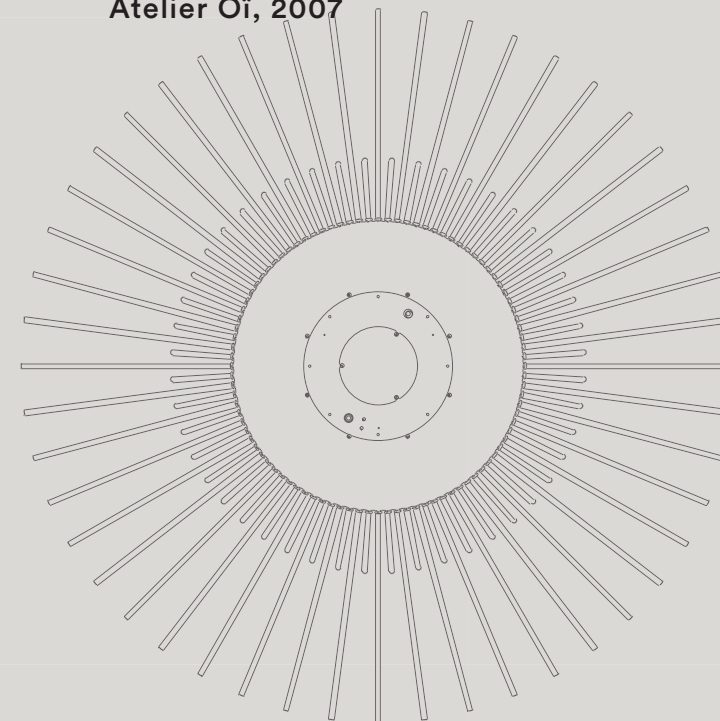

Allegro, sinfonia di luci e ombre. A prima vista può sembrare uno strumento musicale o una sorprendente scenografia che si libra nell'aria, in realtà è un modo del tutto speciale di illuminare e caratterizzare lo spazio.

Allegro, a symphony of lights and shadows. At first glance it may look like a musical instrument or a stunning set-up that soars into the air, but in reality Allegro has a very special way of lighting and decorating a space.

Lights & shadows



Allegro è un progetto che accosta linee sottili, realizzate con tubi di alluminio, in forme tridimensionali, sospese e immateriali, attraverso le quali la luce si diffonde nell'ambiente, vestendolo di magici giochi d'ombre.

Allegro is a project that combines thin lines, made of aluminium tubes, into suspended and immaterial three-dimensional shapes, through which the light is cast into the room, adorning it with magical games of shadows.

Gravity

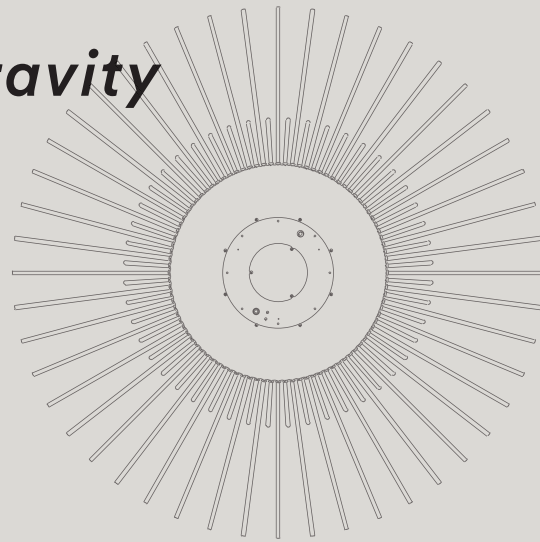

Allegro — Atelier Oï, 2007

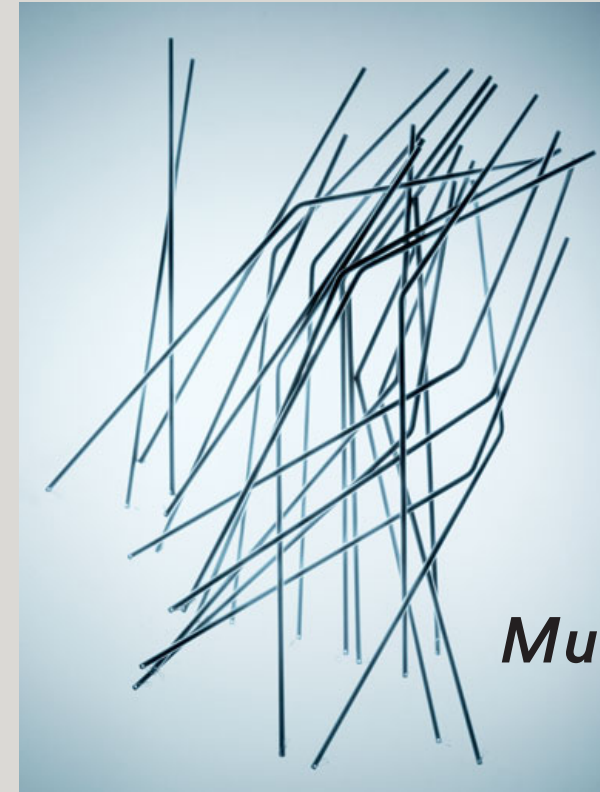

Come le note musicali, Allegro si presta a infinite composizioni, intime, romantiche o maestose: Allegro Ritmico, Vivace, Assai ed ancora altre tipologie, ambientabili da sole oppure in gruppo, in casa come negli spazi dedicati al grande pubblico, in tutto il mondo.

Like musical notes, Allegro lends itself to endless compositions, whether cosy and intimate, romantic or majestic: Allegro Ritmico, Vivace, Assai and other types too, which can be used alone or in multiple compositions, at home as well as in settings for the general public, all over the world.

Textes en français, Deutsche Texte, Textos en español → p. 343

Musical

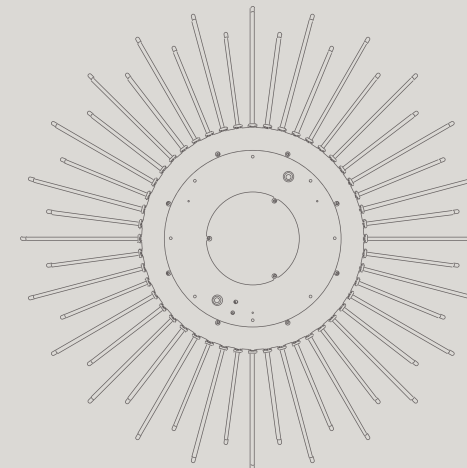



Allegro

Atelier Oi, 2007

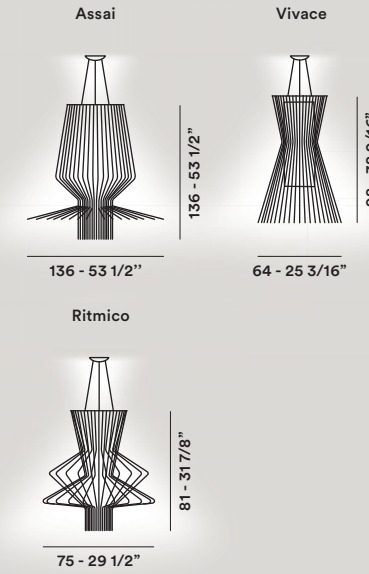

Alluminio verniciato e metallo cromato.
Varnished aluminium and metal.

LED 63W 3000°K 5000 lm included
Energy class A+

Dimmerabile — *Dimmable*
Doppia accensione — *Double switch*

220 / 240V: halo 1x100W E27
+ halo 1x230W R7s
120V: halo 1x75W E26
+ halo 1x200W RSC
Energy class C

IP 20 — (halo)

Assai oro, Vivace marrone, Ritmico nero.
Assai gold, Vivace brown, Ritmico black.

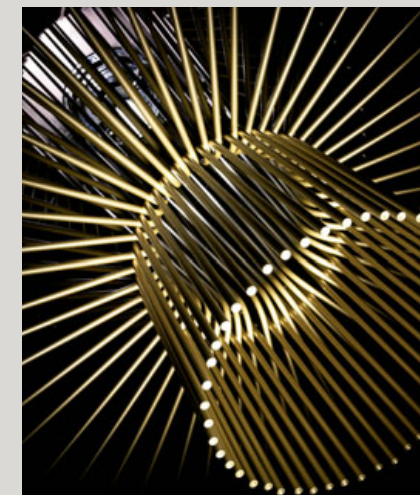
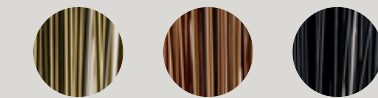



Allegretto

Atelier Oï, 2009



Assai



76 - 29 7/8"

Vivace



50 - 19 7/8"

Ritmico

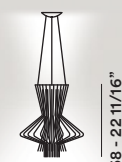

51 - 20 1/8"

Alluminio verniciato e metallo cromato.
Varnished aluminium and metal.

LED E27/E26

220 / 240V: halo 2x100W E27
120V: halo 2x75W E26
Energy class A+, A, B, C



Assai oro, Vivace marrone, Ritmico nero.
Assai gold, Vivalce brown, Ritmico black.

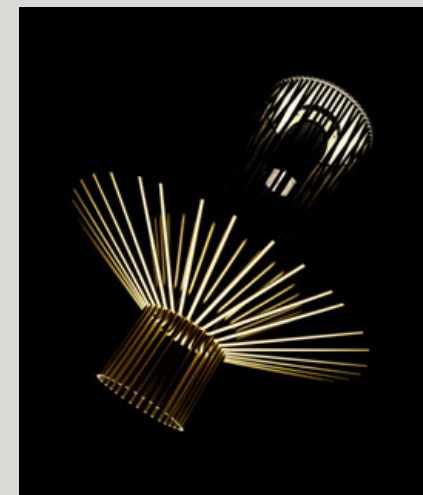
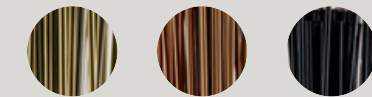



Aplomb

Paolo Lucidi e Luca Pevere, 2010

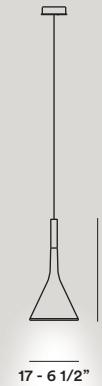

Cemento e alluminio.
Concrete and aluminium.

LED GU10
Energy class A+, A

220 / 240V: halo 1x60W G9
120V: halo 1x60W G9
Energy class C

⊕ ⚡ IP 20 — Ⓞ (GU10)

Bianco, grigio cemento, marrone.
White, concrete grey, brown.



collection →

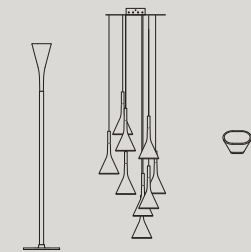

p. 072

p. 214

p. 264



Behive

Werner Aisslinger, 2012

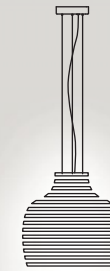

39 - 15 1/4"

39 - 15 1/4"

ABS masterizzato e policarbonato.
Batch-dyed ABS and polycarbonate.

LED E27/E26

220 / 240V: halo 1x150W E27,
fluo 1x25W E27
120V: halo 1x150W E26,
fluo 1x26W E26
Energy class A+, A, B, C

☐ ⚡ IP 20

Bianco. *White.*



collection →



p. 022

Lampada da sospensione, soffitto e parete — *Suspension, ceiling and wall lamp*

Big Bang

Enrico Franzolini con Vicente Garcia Jimenez, 2005



Big Bang, forza esplosiva. Solo Foscarini poteva trasformare un'idea così estrema, inedita, ispirata all'arte contemporanea ed all'architettura d'avanguardia, in una lampada di grandissimo successo.

Big Bang, explosive force. Only Foscarini could turn such an extreme and innovative idea inspired by contemporary art, and cutting-edge architecture into a highly successful lamp.

Explosion

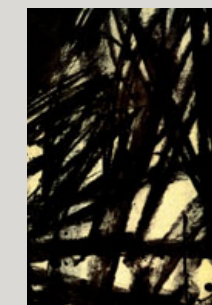

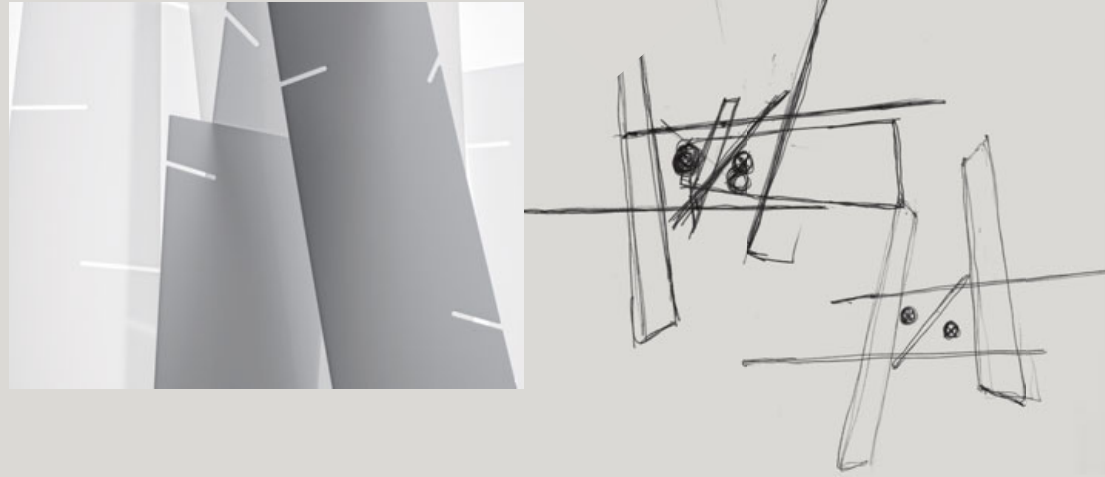

Realizzata in metacrilato e alluminio verniciato, Big Bang è un'esplosione di piani che si intersecano, creando molteplici giochi di luci e ombre, con un'illuminazione diretta e riflessa allo stesso tempo.

Made of methacrylate and painted aluminium, Big Bang is an explosion of criss-crossing forms which create multiple interplays of light and shadow, with direct and concurrently reflected light.

Sculptural



Big Bang — Enrico Franzolini con Vicente Garcia Jimenez, 2005

Un effetto ulteriormente sottolineato nella versione bicolore, oppure reso più sfumato in quella monocromatica, per una lampada che, in ogni caso, non nasce per passare inosservata. Inoltre, nella nuova versione a LED, all'inconfondibile presenza scenica e illuminotecnica, si aggiunge un'ancora maggiore efficienza energetica.

This effect is further emphasised in the two-colour version, or lent a softer hue in the monochromatic white. A lamp that was not born to go unnoticed in any circumstance. What's more, in the new LED version, a greater energy efficiency is added to its unmistakable scenic lighting presence.

Textes en français, Deutsche Texte, Textos en español → p. 343

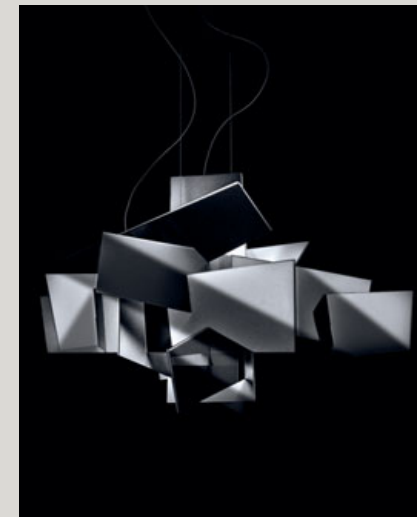

Signal

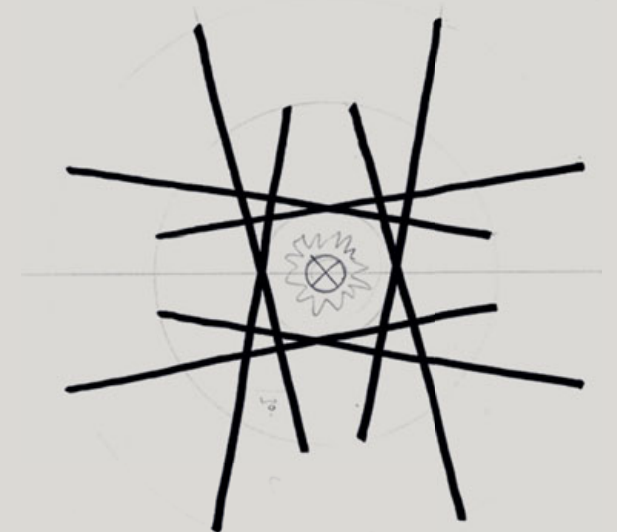
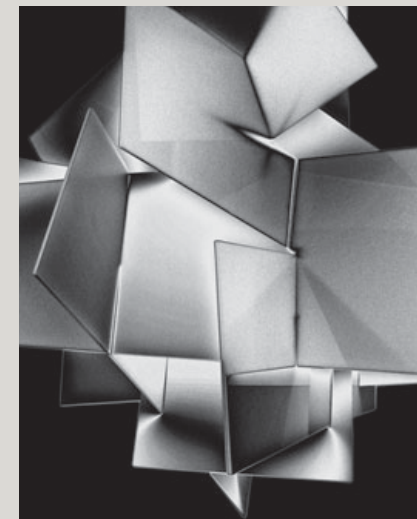

Big Bang

LED

Enrico Franzolini con Vicente Garcia Jimenez, 2005

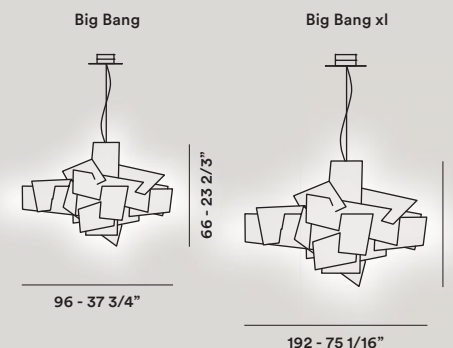

Metacrilato e alluminio verniciato.
Methacrylate and varnished aluminium.

Big Bang
LED 37,7 W 3000° K 3260 lm included
Energy class A+

220 / 240V: halo 1x160W R7s,
fluo 1x26W GX24q-3
120V: halo 1x200W RSC,
fluo 1x26W GX24q-3
Energy class C (halo)
Energy class A+, A (fluo)

Big Bang xl
220 / 240V: halo 1x160W R7s
Energy class C

⊕ ⚡ UL LISTED IP 20 — (halo)

Bianco, rosso.
White, red.



collection →

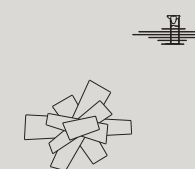



Lampada da tavolo, terra, sospensione, soffitto e parete — *Table, floor, suspension, ceiling and wall lamp*

Caboche

Patricia Urquiola con Eliana Gerotto, 2005

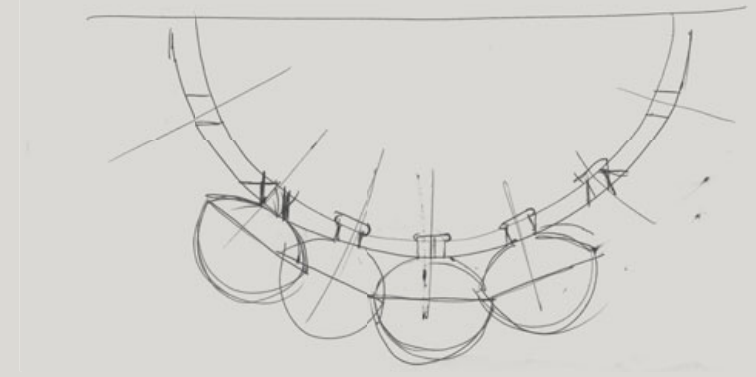

Caboche, gioiello di design. Le donne sanno sempre cogliere gli aspetti più inattesi delle cose. Quando poi si tratta di due donne designer, dalla loro creatività non può nascere altro che una lampada tanto sorprendente, quanto affascinante: Caboche.

Caboche, design gem. Women always know how to make the most out of the unexpected. When these women are two designers, their combined creativity could not lead to anything other than a charming and disarming lamp: Caboche.

Jewel

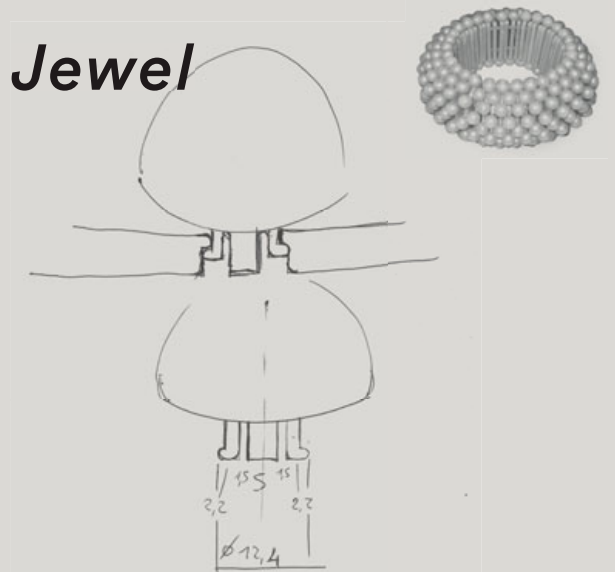

Caboche — Patricia Urquiola con Eliana Gerotto, 2005



La sua forma prende ispirazione da un bracciale di perle, ma si trasforma in una composizione di sfere trasparenti, scintillanti come diamanti ma realizzate con un materiale leggero, resistente e tecnologicamente contemporaneo: il polimetilmetacrilato, in versione cristallo o giallo oro.



Its shape was inspired by a pearl bracelet, but it turns into a composition of sparkling transparent spheres, gleaming like diamonds but made with a lightweight, hard-wearing and technologically contemporary material: polymethylmethacrylate or PMMA, in transparent or yellow gold version.

Prototipi — Prototypes

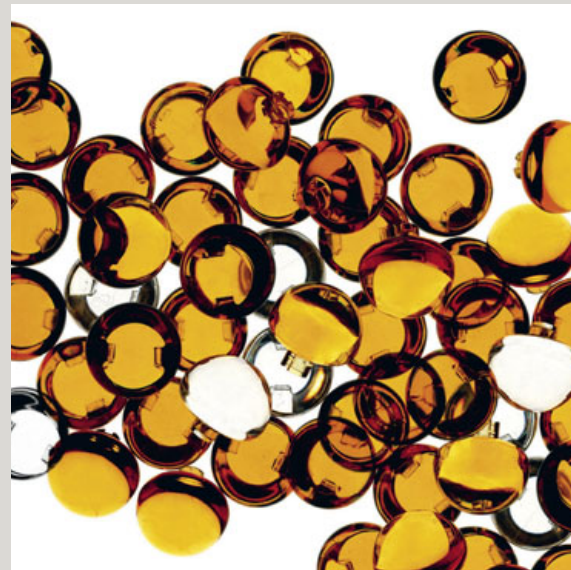
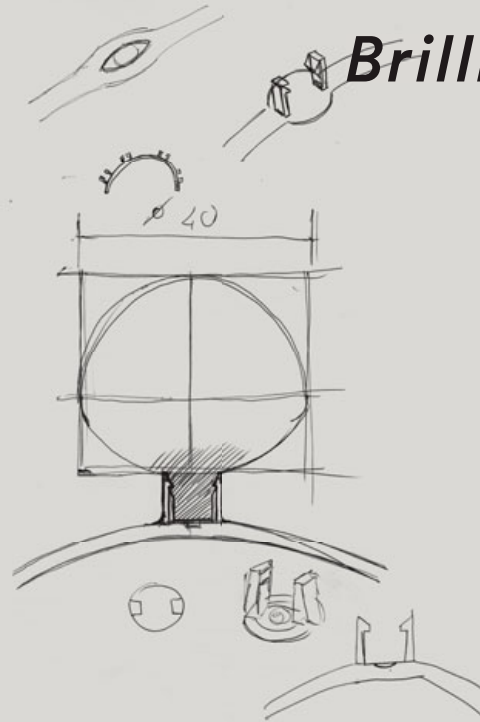

Le sfere possono dare vita a lampade di varie misure, dal piccolo modello a sospensione, alla grande installazione, creando irresistibili gioielli luminosi che aggiungono un fascino prezioso agli ambienti più diversi.

The spheres can form lamps of various sizes, from a small suspension model to a large installation, creating irresistible luminous gems that add precious charm to the most disparate settings.

Textes en français, Deutsche Texte, Textos en español → p. 343

Transparent

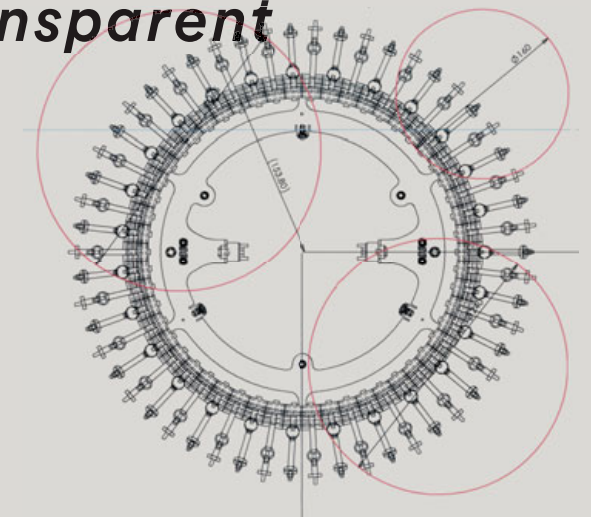

Caboche

Patricia Urquiola con Eliana Gerotto, 2005

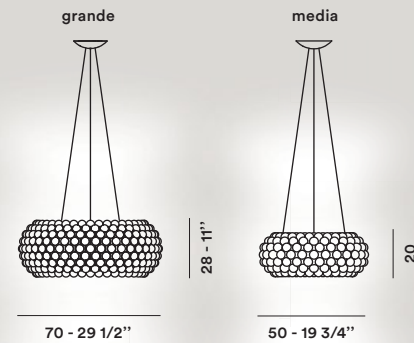

Polimetilmetacrilato, vetro soffiato, metallo cromato e alluminio (LED).
PMMA, blown glass, chromed metal and aluminium (LED).

Caboche grande
 220 / 240V: LED 46W 3000° K 4330 lm
 120V: 54W 3000° K 5051 lm
Energy class A+
 Dimmerabile — *Dimmable*

220 / 240V: halo 1x230W R7s
 120V: halo 1x200W RSC
Energy class C

Caboche media
 LED 35W 3000° K 3062 lm included
Energy class A+
 Dimmerabile — *Dimmable*

220 / 240V: halo 1x160W R7s
 120V: halo 1x150W RSC
Energy class C

⚡ ⚙️ Ⓛ Ⓜ Ⓜ IP 20 — (halo)

Trasparente, giallo oro.
Transparent, gold yellow.



collection →

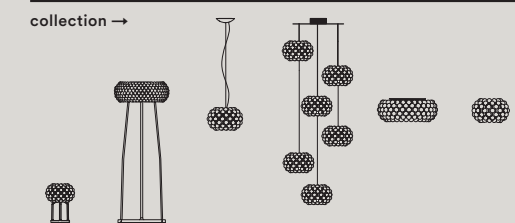

p. 030 p. 076 p. 154 p. 214 p. 240 p. 284

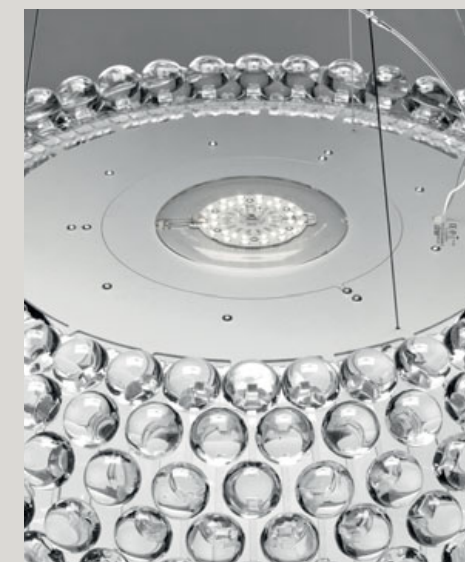



Caboche piccola

Patricia Urquiola con Eliana Gerotto, 2005



Polimetilmetacrilato, vetro soffiato e metallo cromato.
PMMA, blown glass, chromed metal.

220 / 240V: halo 1x60W G9
120V: halo 1x60W G9
Energy class C

 IP 20

Trasparente, giallo oro.
Transparent, gold yellow.

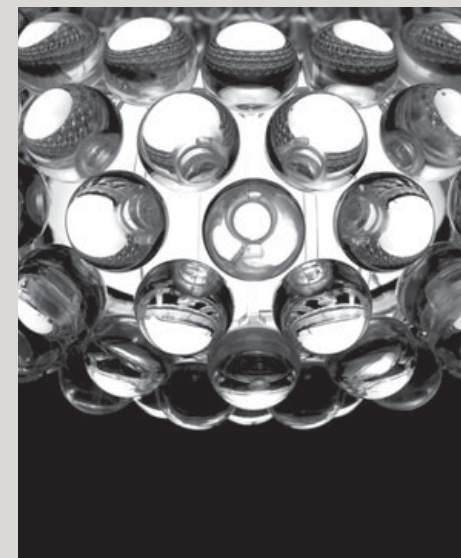

collection →

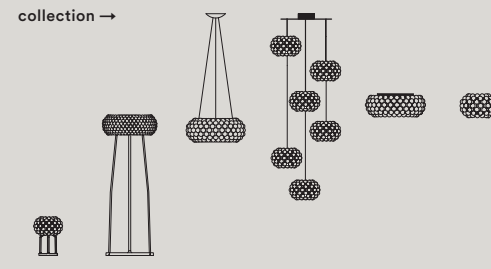

p. 030 p. 076 p. 152 p. 214 p. 240 p. 284



Chouchin

Ionna Vautrin, 2011

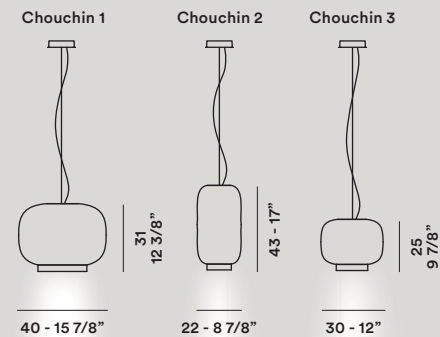

Vetro soffiato verniciato.
Lacquered blown glass.

LED E27/E26

220 / 240V: halo 1x100W E27,
halo 1x150W E27, fluo 1x25W E27
120V: halo 1x75W E26,
halo 1x150W E26, fluo 1x26W E26
Energy class A+, A, B, C



Chouchin 1 arancio, Chouchin 2 verde,
Chouchin 3 grigio.
*Chouchin 1 orange, Chouchin 2 green,
Chouchin 3 grey.*

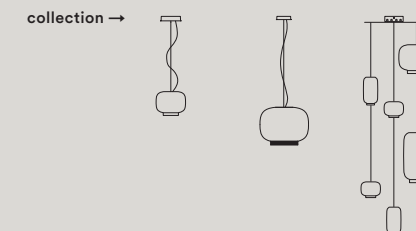

Chouchin mini

Ionna Vautrin, 2013

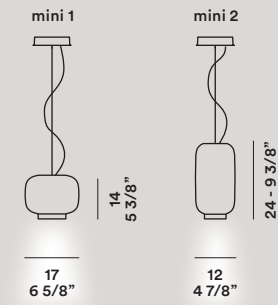

Vetro soffiato verniciato.
Lacquered blown glass.

LED GU10

220 / 240V: halo 1x35W GU10
120V: halo 1x35W GU10
Energy class A++, A+, A, B, C

⊕ ⚡ IP 20

Chouchin 1 arancio, Chouchin 2 verde.
Chouchin 1 orange, Chouchin 2 green.



collection →

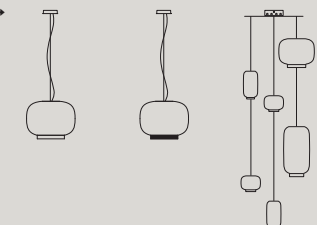

p. 156

p. 160

p. 214

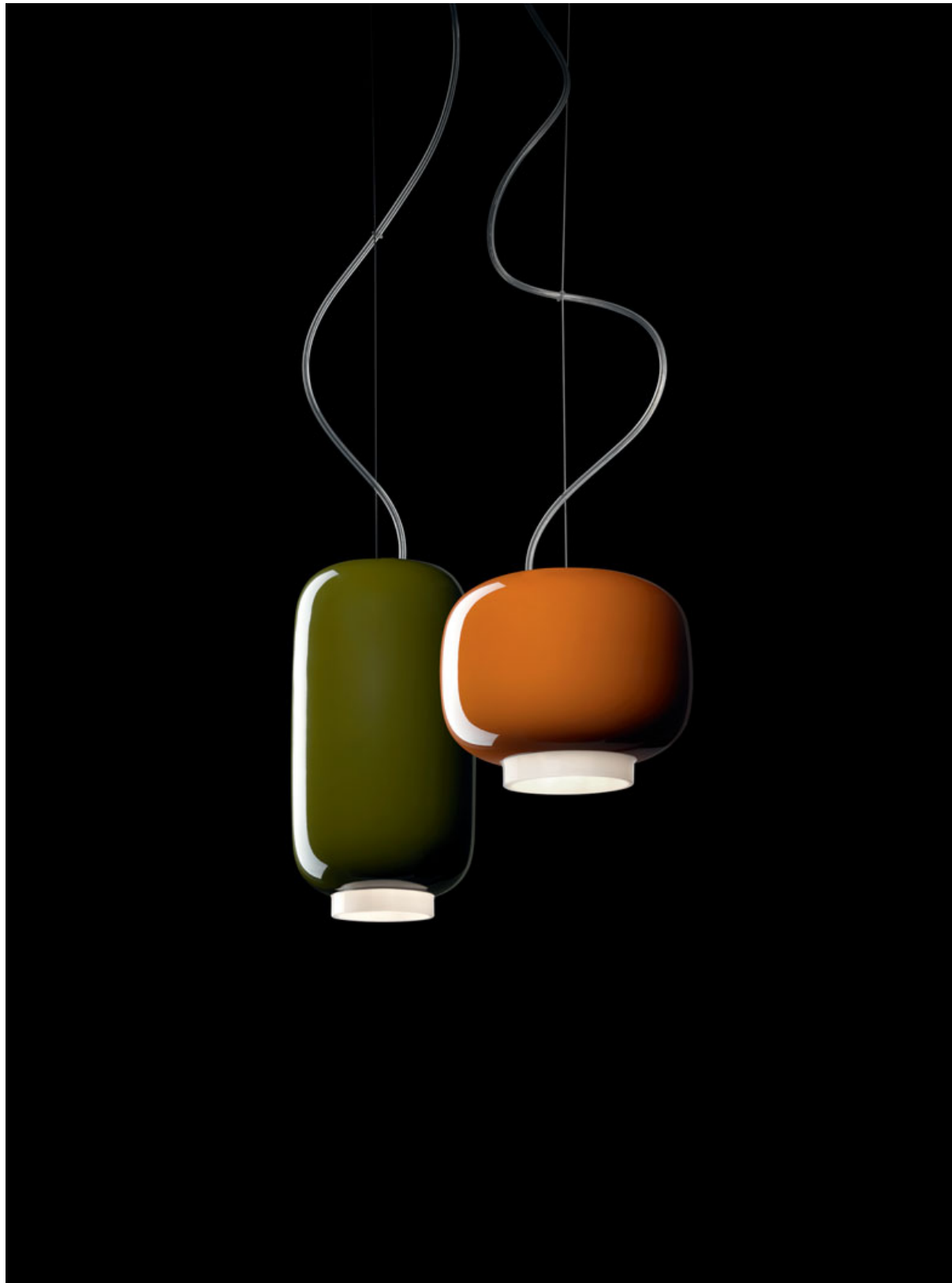

Chouchin reverse

Ionna Vautrin, 2015

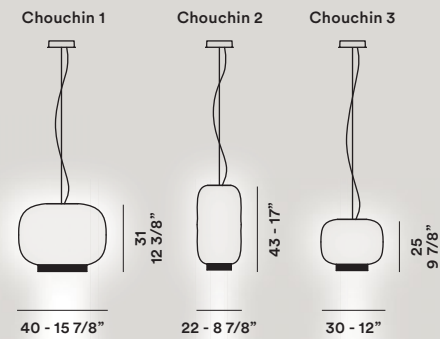

Vetro soffiato verniciato.
Lacquered blown glass.

LED E27/E26

220 / 240V: halo 1x150W E26,
fluo 1x26W E26
120V: halo 1x150W E27,
fluo 1x25W E27
Energy class A+, A, B, C

⊕ ⚡ IP 20

Chouchin 1 Bianco / arancio, Chouchin 2
bianco / verde, Chouchin 3 bianco / grigio.
*Chouchin 1 white / orange, Chouchin 2 white /
green, Chouchin 3 white / grey.*

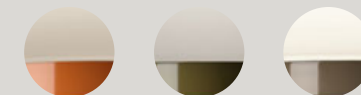

collection →

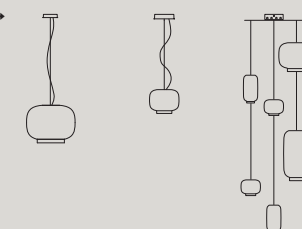

p. 156

p. 158

p. 214



Giga-Lite

Marc Sadler, 2004

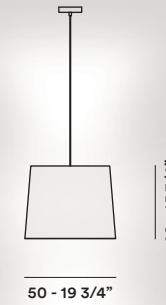

Tessuto di vetro con fibra di carbonio e metallo nichelato.
Fiberglass fabric with carbonium thread and nickelplated metal.

LED E27/E26

220 / 240V: halo 3x77W E27,
fluo 3x20W E27
120V: inc 3x100W E26,
fluo 3x20W E26
Energy class A+, A, B, C



Nero. *Black.*



collection →

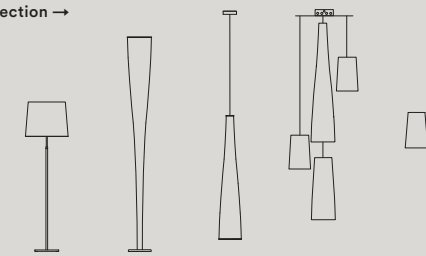

p. 080

p. 100

p. 194

p. 214

p. 310



Gregg

Ludovica e Roberto Palomba, 2007

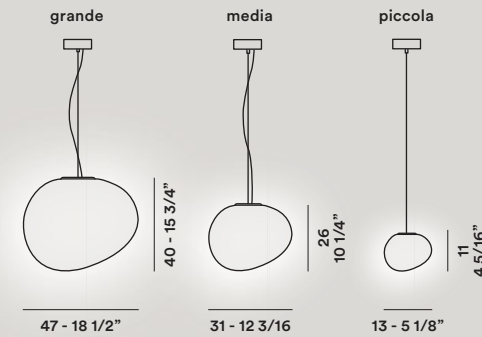

Vetro soffiato satinato.
Blown acid-etched glass.

Gregg grande
LED E27/E26

220 / 240V: halo 1x205W E27, fluo 1x30W E27
120V: halo 1x150W E26, fluo 1x26W E26
Energy class A+, A, B, C

Gregg media
LED E27/E26

220 / 240V: halo 1x150W E27, fluo 1x25W E27
120V: halo 1x100W E26, fluo 1x26W E26
Energy class A+, A, B, C

IP 20 — (grande - media)

Gregg piccola
220 / 240V: halo 1x33W G9
120V: halo 1x40W G9
Energy class C

IP 20

Bianco. *White.*

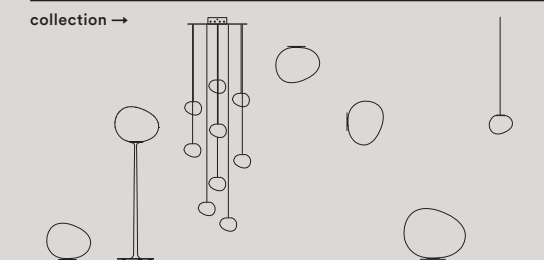

p. 036 p. 082 p. 214 p. 250 p. 304 p. 332 p. 330



Havana

Jozeph Forakis, 1993

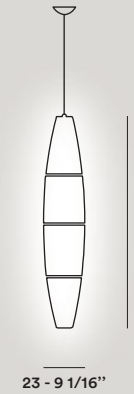

Polietilene stampato a iniezione e metallo verniciato.
Injection moulded polyethylene and varnished metal.

LED E27/E26

220 / 240V: halo 1x105W E27,
fluo 1x25W E27
120V: inc 1x100W E26,
fluo 1x25W E26
Energy class A+, A, B, C



Bianco. *White.*



collection →

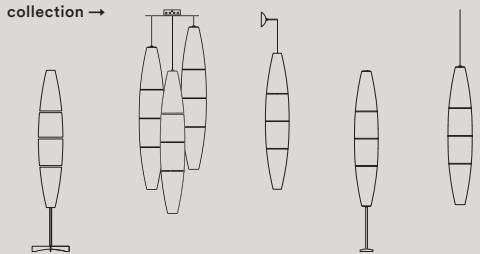

p. 088

p. 214

p. 306

p. 336

p. 334



Jamaica

Marc Sadler, 2011

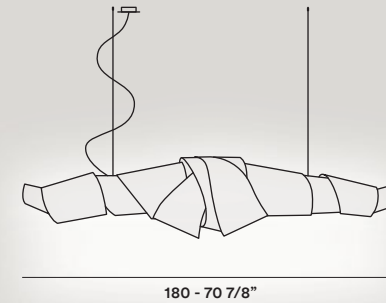

35 - 13 3/8"

Carta accoppiata con tecnopolimero,
PMMA e metallo verniciato.
*Paper tape coupled with techopolymer,
PMMA and varnished metal.*

Dimmerabile — *Dimmable*

220 / 240V: fluo max 2x80W G5
120V: fluo 2x80W mini Bi-Pin
Energy class A+, A



Bianco. *White.*

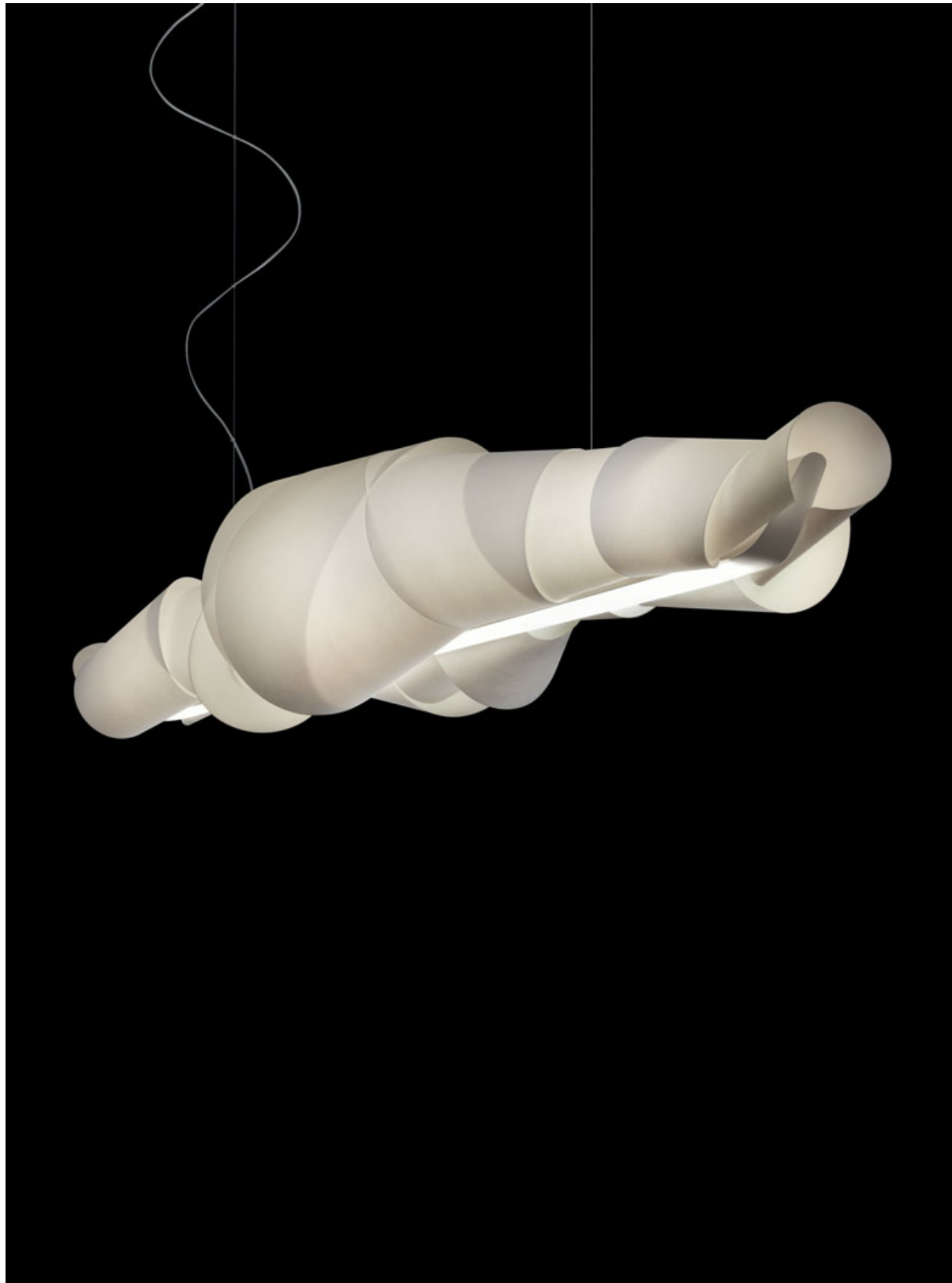

Le Soleil

Vicente Garcia Jimenez, 2009



43 - 17"

62 - 24 7/32"

Policarbonato stampato ad iniezione e metallo verniciato.
Injection moulded polycarbonate and coated metal.

220 / 240V: halo 3×60W G9 + halo 1×75W GU10, fluo 1×42W GX24q-4
120V: halo 3×75W G9 + halo 1×75W GU10, fluo 1×42W GX24q-4
Energy class A+, A, C

   IP 20 —  (halo)

Bianco, acquamarina, rosso.
White, aquamarine, red.



collection →



p. 314



Lightweight

Tom Dixon, 1995

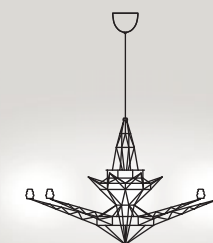

73 - 28 3/4"

116 - 45 21/32"

Metallo anodizzato.
Anodised metal.

220 / 240V: halo 8x20W G4
120V: halo 8x20W G4
Energy class C

⊕ IP 20

Anodizzato. *Anodized.*

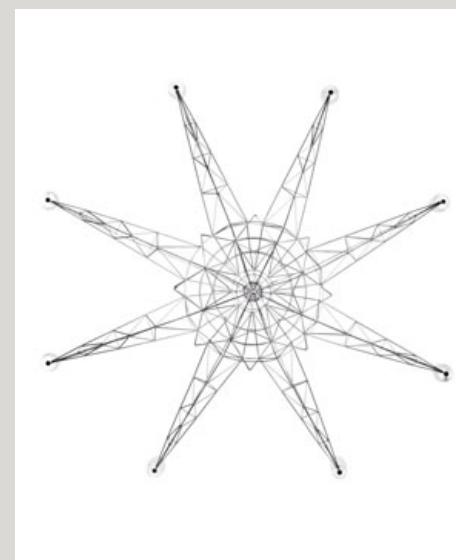

Maki

Nendo, 2011



Alluminio verniciato.
Lacquered aluminium.

LED GU10

220 / 240V: halo 1x35W GU10
120V: halo 1x35W GU10
Energy class A++, A+, A, B, C



Bianco, grigio.
White, grey.



collection →



p. 214





New Buds

Rodolfo Dordoni, 2007

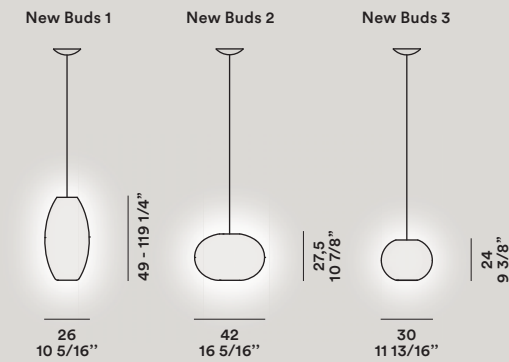

Vetro soffiato.
Blown glass.

LED E27/E26

220 / 240V: halo 1x150W E27,
fluo 1x25W E27
120V: inc 1x100W E26,
fluo 1x26W E26
Energy class A+, A, B, C



New Buds 1 grigio, New Buds 2 avorio,
New Buds 3 ambra.
*New Buds 1 grey, New Buds 2 ivory,
New Buds 3 amber.*



collection →

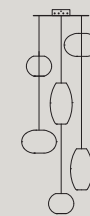

O-Space

Luca Nichetto e Gianpietro Gai, 2003



56 - 22"

29
11 3/8"

Poliuretano espanso e metallo cromato.
Expanded polyurethane and chrome metal.

220 / 240V: halo 1x120W R7s

120V: halo 1x150W RSC

Energy class C

   IP 20

Bianco. *White.*





Planet

Changedesign, 2011



grande



80 - 31 1/2"

piccola



55 - 21 5/8"

Polietilene tereftalato e nylon.
Polyethylene terephthalate and nylon.

LED E27/E26

Planet grande
220 / 240V: halo 1x150W E27,
fluo 1x25W E27
120V: halo 1x150W E26,
fluo 1x26W E26
Energy class A+, A, B, C

Planet piccola
220 / 240V: halo 1x105W E27,
fluo 1x25W E27
120V: halo 1x100W E26,
fluo 1x26W E26
Energy class A+, A, B, C

  IP 20

Bianco, rosso.
White, red.

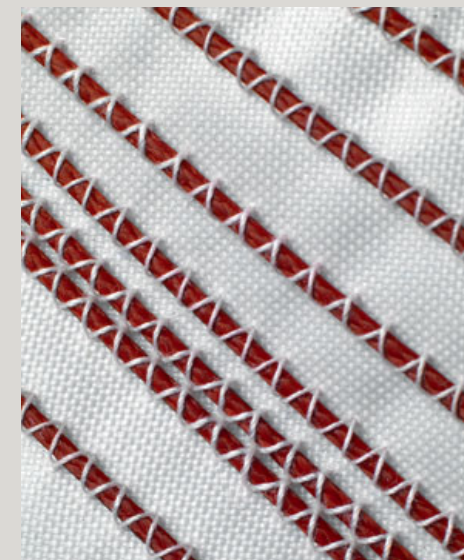



Plass grande

Luca Nichetto, 2011



115 - 45"

75 - 29 1/2"

Policarbonato stampato in rotazionale e alluminio.
Rotational moulded polycarbonate and aluminium.

LED 30W 3000° K 2500 lm included,
LED 1x12W E27
Energy class A+, A

Doppia accensione — *Double switch*

220 / 240V: halo 6x60W G9 + halo 1x100W E27
120V: halo 6x60W G9 + halo 1x75W E26
Energy class C



Grigio, azzurro.
Grey, blue.

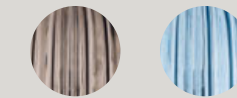

collection →

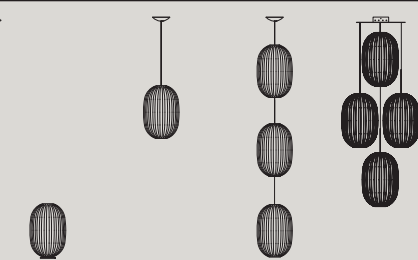

p. 050

p. 184

p. 185

p. 214

Plass media

Luca Nichetto, 2015



34 - 13 1/4"

50 - 19 1/2"

Policarbonato stampato in rotazionale e acciaio.
Rotational moulded polycarbonate and steel

LED E27/E26

220 / 240V: halo 1x116W E27 + halo 1x75W GU10
120V: halo 1x100W E26 + halo 1x50W GU10
Energy class A+, A, B, C



Grigio, azzurro.
Grey, blue.

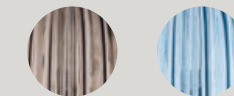

collection →



p. 050

p. 182

p. 214



Rituals

Ludovica e Roberto Palomba, 2013

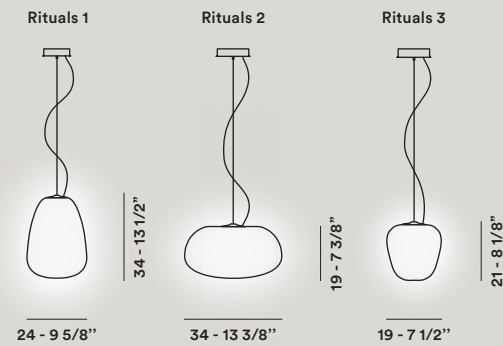

Vetro soffiato satinato inciso e metallo verniciato.
Blown engraved satin glass and lacquered metal.

LED E27/E26

220 / 240V: fluo 1x15W E27,
halo 1x70W E27,
halo 1x60W G9
120V: fluo 1x15W E26,
halo 1x60W E26,
halo 1x60W G9
Energy class A+, A, B, C



Bianco. *White.*



collection →

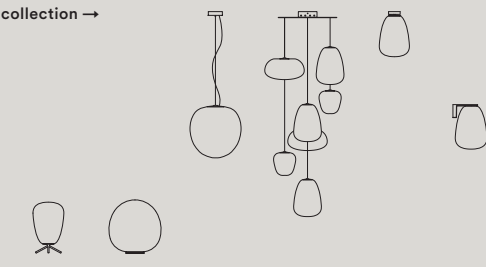

p. 058 p. 060 p. 188 p. 214 p. 256 p. 320



Rituals xl

Ludovica e Roberto Palomba, 2015



Vetro soffiato satinato inciso e metallo verniciato.
Blown engraved satin glass and lacquered metal.

LED E27/E26

220 / 240V: halo 1x150W E27,
fluo 1x25W E27

120V: halo 1x100W E26,
fluo 1x26W E26

Energy class A+, A, B, C



Bianco. *White.*



collection →

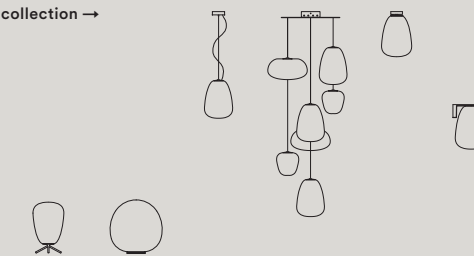

p. 058

p. 060

p. 186

p. 214

p. 256

p. 320





Spokes

Garcia Cumini, 2015

LED

Spokes 1



32,5 - 12 3/4"

Spokes 2



52 - 20 1/2"

Acciaio e alluminio verniciato.
Varnished steel and aluminium.

LED 35W 2700° K 2780 lm included
Dimmerabile — *Dimmable*
Energy class A+

   IP 20

Bianco, Giallo oro.
White, Gold yellow.

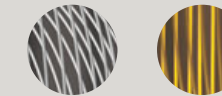

Supernova

Ferruccio Laviani, 2000



50 - 19 3/4"

60 - 23 3/4"

Alluminio verniciato.
Lacquered aluminium.

LED E27/E26

220 / 240V: fluo 1x23W E27
120V: inc 1x100W E26
Energy class A+, A, B, C

  IP 20

Alluminio, fucsia.
Aluminium, fuchsia.

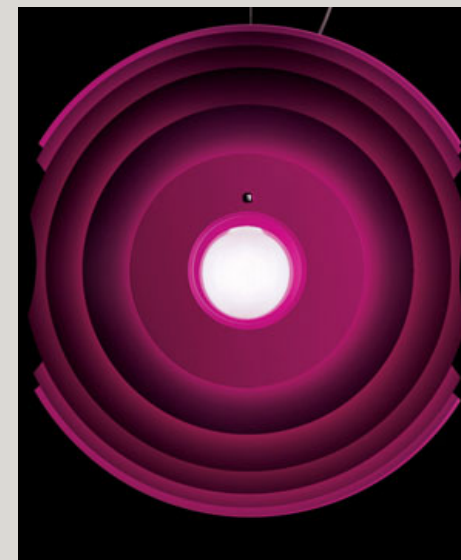



Tite

Marc Sadler, 2000



Tite 1

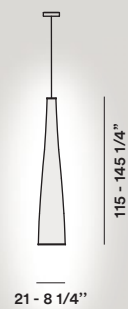

Tite 2

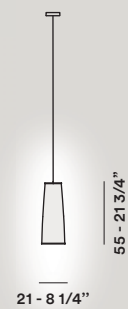

Tessuto di vetro, fibra di carbonio e acciaio nichelato.
Fiberglass fabric with carbonium thread and nickel-plated steel.

LED E27/E26

220 / 240V: halo 1x116W E27,
fluo 1x25W E27
120V: inc 1x100W E26,
fluo 1x26W E26
Energy class A+, A, B, C



Nero. *Black.*



collection →

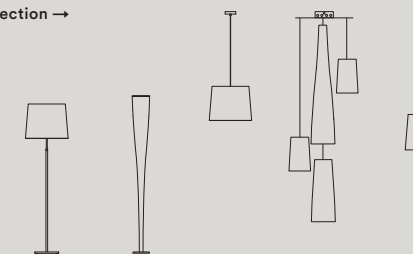

p. 080

p. 100

p. 162

p. 214

p. 310



Tress

Marc Sadler, 2009

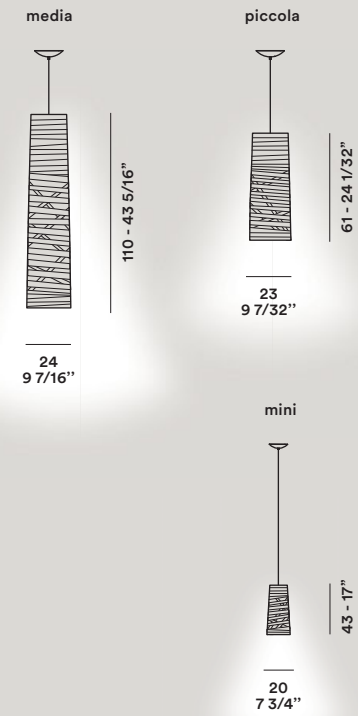

Materiale composito su base di fibra di vetro verniciato e metallo cromato.
Varnished fibreglass based composite material and chromed metal.

Tress media / piccola
LED E27/E26
220 / 240V: halo 1x100W E27
120V: halo 1x75W E26
Energy class C

Tress mini
LED GU10
220 / 240V: halo 1x75W GU10
120V: halo 1x75W GU10
Energy class C

⚡ ⚙️ Ⓛ Ⓜ Ⓜ IP 20 — Ⓢ (media / piccola)

Bianco, nero, rosso.
White, black, red.

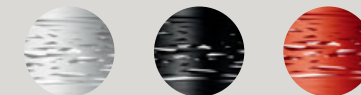

collection →

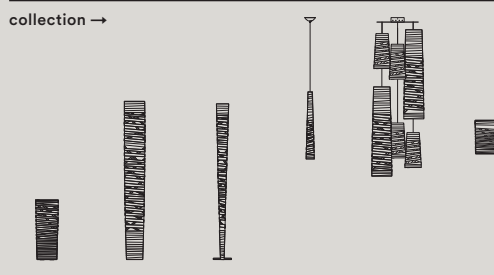

p. 062 p. 110 p. 112 p. 200 p. 214 p. 324



Tress grande

Marc Sadler, 2014



41 - 16"

48 - 19 1/16"

Materiale composito su base di fibra di vetro verniciato, vetro soffiato acidato e alluminio.
Coated fibreglass based composite material, blown acid-etched glass and aluminium.

LED 35W 3000° K 3062 lm included
Energy class A+

Dimmerabile — *Dimmable*

220 / 240V: halo 1x160W R7s
120V: halo 1x200W RSC
Energy class C

   IP 20 —  (halo)

Bianco, nero, rosso.
White, black, red.

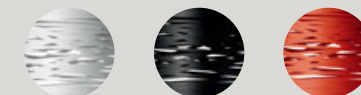

collection →

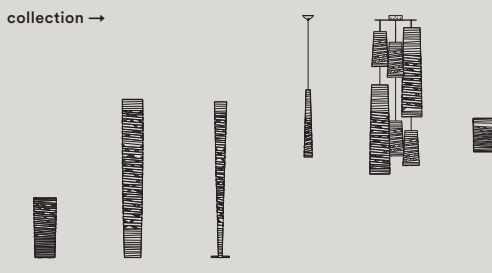

p. 062 p. 110 p. 112 p. 200 p. 214 p. 324



Tress Stilo

Marc Sadler, 2011

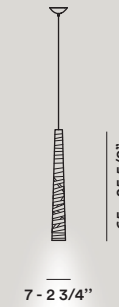

Materiale composito su base di fibra di vetro verniciato, acciaio inox e policarbonato.
Varnished fibreglass based composite material, stainless steel and polycarbonate.

LED GU10

220 / 240V: halo 1x35W GU10
120V: halo 1x35W GU10
Energy class A+, A, B, C



Bianco, nero, rosso.
White, black, red.

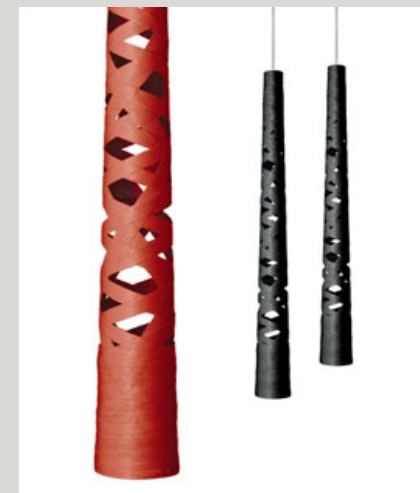
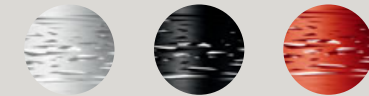

collection →

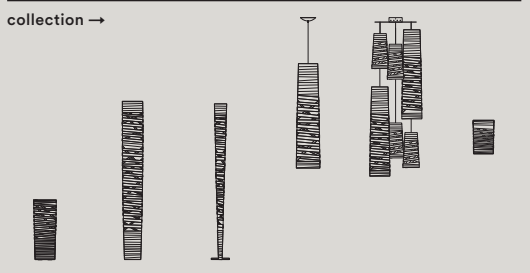

p. 062 p. 110 p. 112 p. 196 p. 214 p. 324



Troag

Luca Nichetto, 2010

grande

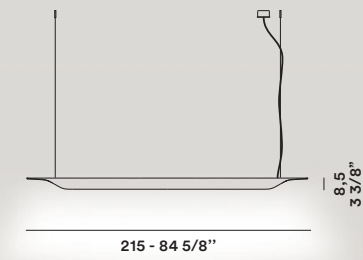

media

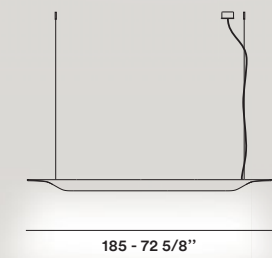

piccola

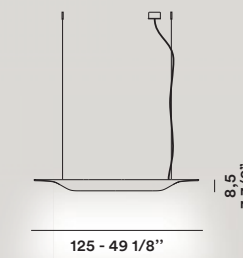

Multistrato di legno curvato e PMMA.
Curved plywood and PMMA.

Troag grande
220 / 240 / 120V: fluo 1x80W G5
Energy class A+, A

Troag media
220 / 240 / 120V: fluo 1x54W G5
Energy class A+, A

Troag piccola
220 / 240 / 120V: fluo 1x24W G5
Energy class A+, A



Nero, naturale.
Black, natural.



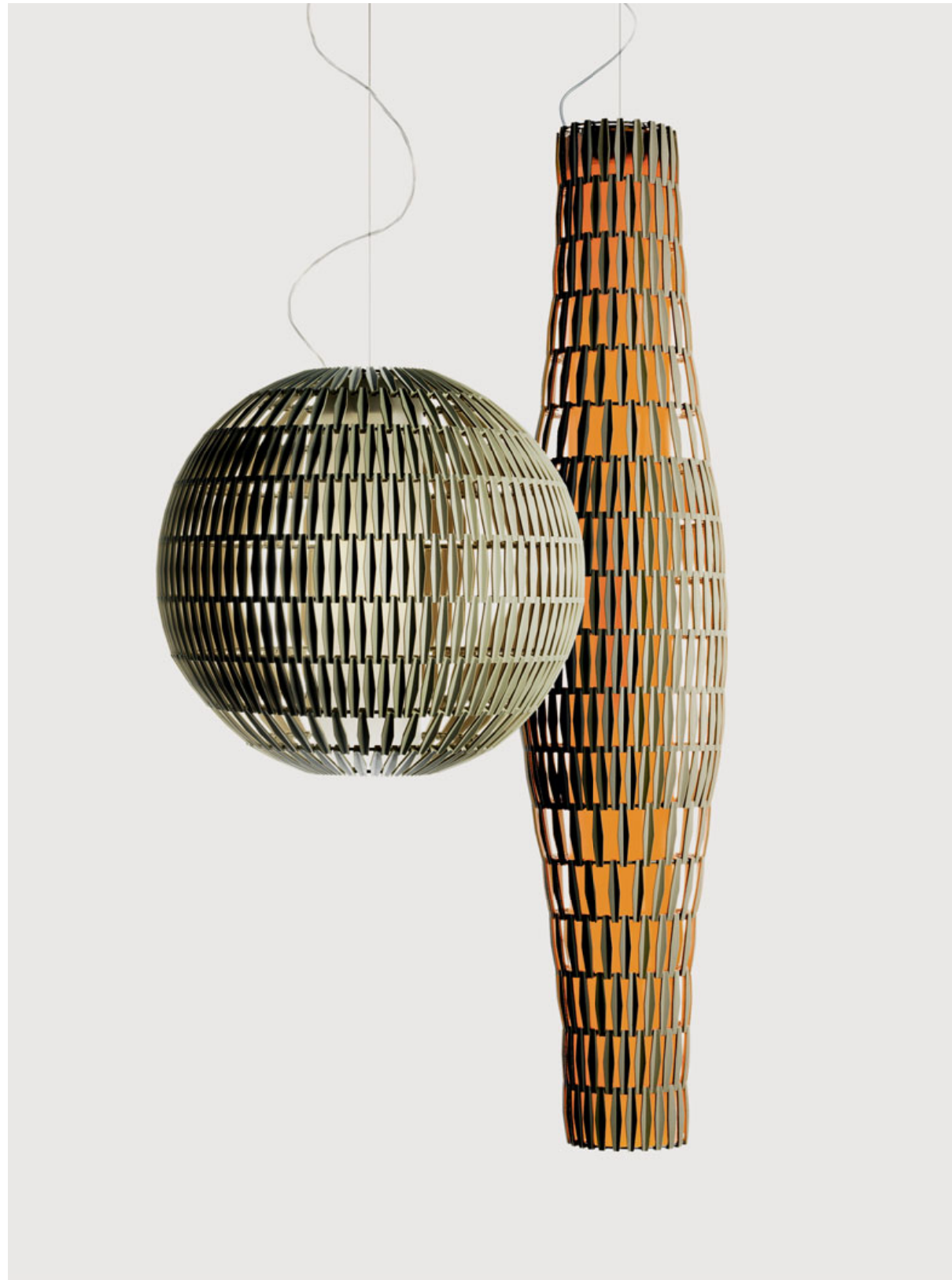

Tropico

Giulio Iacchetti, 2008

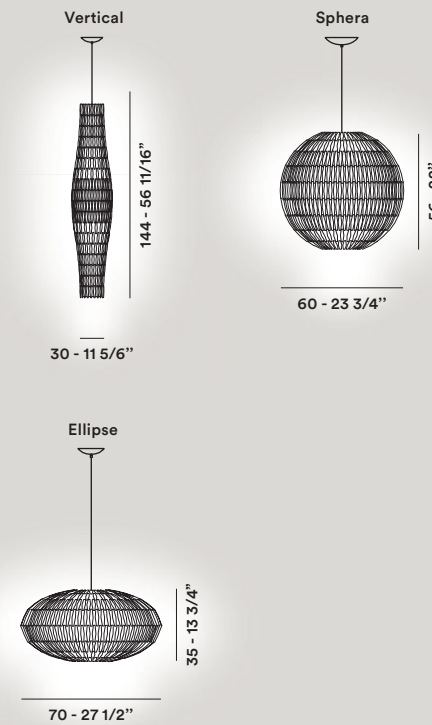

Polycarbonato stampato a iniezione e metallo cromato.
Injection moulded polycarbonate and chromed metal.

Tropico Vertical
220 / 240V: fluo 1x40W 2G11
120V: fluo 1x36W 2G11
Energy class A+, A

Tropico Sphera / Ellipse
220 / 240V: fluo 1x42W GX24q-4
120V: fluo 1x42W GX24q-4
Energy class A+, A

A richiesta filtri colorati
— *Colored filters on request*



Ghiaccio, avorio.
Ice, ivory.





Twiggy

Marc Sadler, 2007

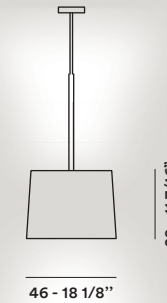

29 - 11 7/16\"/>

Materiale composito su base di fibra di vetro verniciato, policarbonato, PMMA e acciaio.
Coated fibreglass based composite material, PMMA, polycarbonate and steel.

LED E27/E26

220 / 240V: halo 3x77W E27,
fluo 3x20W E27
120V: inc 3x100W E26,
fluo 3x20W E26
Energy class A+, A, B, C



Bianco, nero.
White, black.

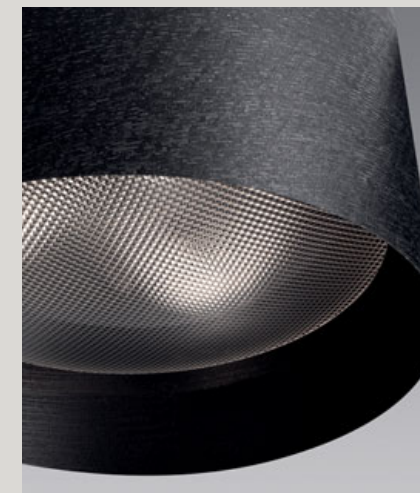

collection →

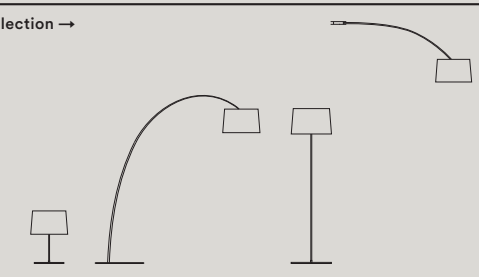

p. 064

p. 124

p. 126

p. 260



Uto

Lagranja Design, 2005

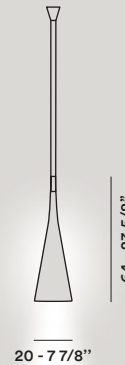

Elastomero termoplastico e policarbonato.
Thermoplastic elastomer and polycarbonate.

LED E27/E26

220 / 240V: fluo 1x15W E27

120V: fluo 1x13W E26

Energy class A+, A

☐ ⚡ IP 44

Suitable for damp location

Bianco, giallo, arancio.
White, yellow, orange.

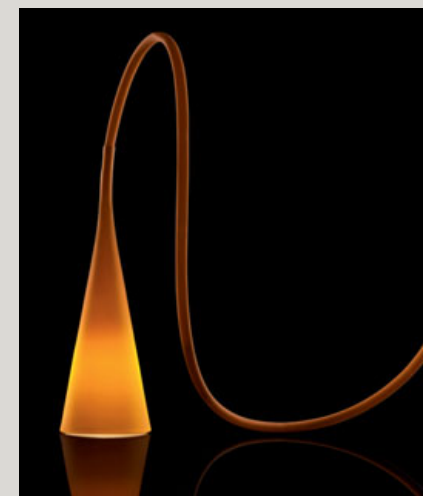

collection →

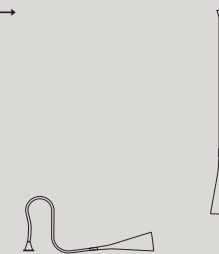

p. 066

p. 340

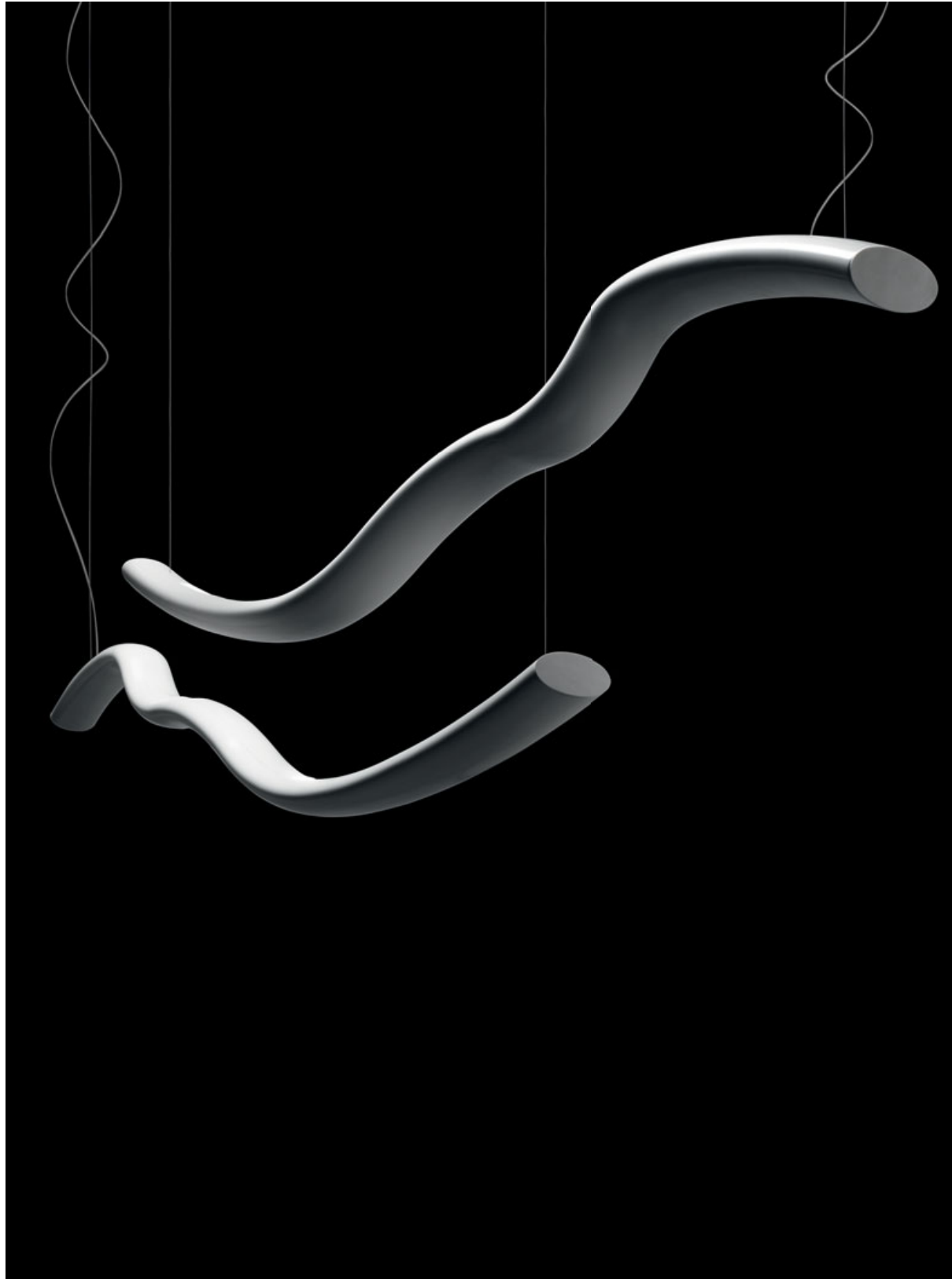

Wave

Studio Baruffi & De Santi, 2009

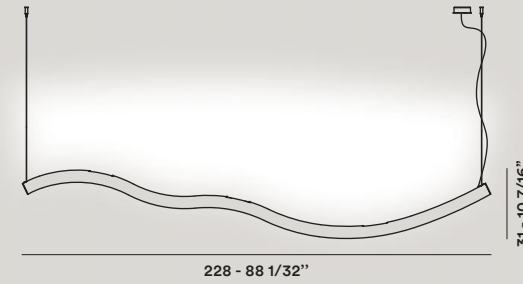

Alluminio laccato.
Lacquered aluminium.

220 / 240V: halo 3×80W R7s
120V: halo 3×100W RSC
Energy class C

   IP 20

Bianco, alluminio.
White, aluminium.



Accessori — Accessories

- 214 - 217 **Rosone Tondo**
— *Round canopy*
- 218 - 221 **Rosone Lineare**
— *Linear canopy*
L 90 - 35 7/16"
- 222 - 225 **Rosone Lineare**
— *Linear canopy*
L 135 - 53 5/32"
- 226 - 227 **Kit decentramento** —
Decentralization kit



Rosone multiplo tondo Round multiple canopy

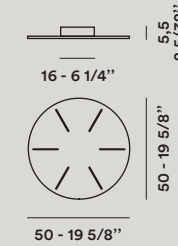

Metallo verniciato. *Laquered metal.*

- Aplomb → max 9
- Caboche piccola → max 6
- Chouchin 1 → max 6
- Chouchin 2 → max 6
- Chouchin 3 → max 6
- Chouchin mini 1 / 2 → max 9
- Gregg media → max 6
- Gregg piccola → max 9
- Havana → max 6
- Maki → max 9
- New Buds 1 / 2 / 3 → max 6
- Plass media → max 6
- Rituals 1 / 2 → max 6
- Rituals 3 → max 9
- Rituals xl → max 6
- Tite 1 / 2 → max 9
- Tress media / piccola → max 6
- Tress mini / Stilo → max 9

Il massimo si riferisce all'installazione di lampade in composizione sfalsata. *Max refers to installation in staggered composition.*

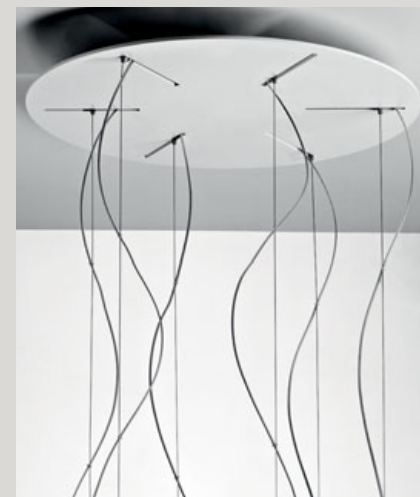

Rosone multiplo tondo — *Round multiple canopy*

Aplomb



Caboche piccola



Rosone multiplo tondo — *Round multiple canopy*

Plass media



New Buds



Chouchin — Chouchin mini



Gregg

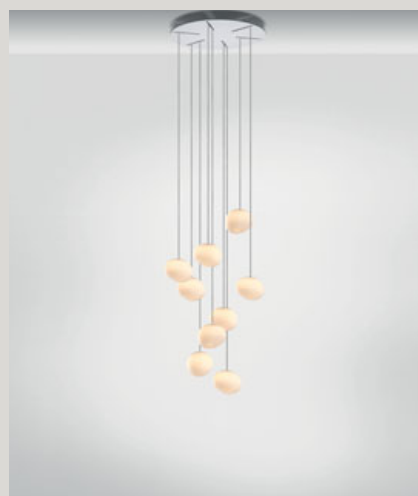

Tite 2

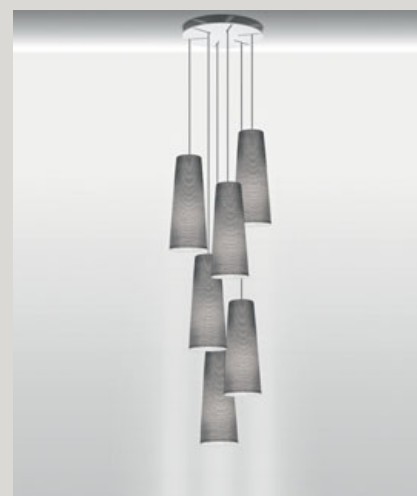

Tress Stilo





Rosone multiplo lineare L 90 *Linear multiple canopy L 35 7/16"*

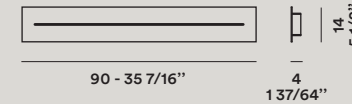

Metallo verniciato. *Laquered metal.*

- Aplomb → max 6
- Caboche piccola → max 5
- Chouchin 1 → max 4
- Chouchin 2 → max 6
- Chouchin 3 → max 5
- Chouchin mini 1 / 2 → max 6
- Gregg media → max 5
- Gregg piccola → max 6
- Havana → max 6
- Maki → max 6
- New Buds 1 → max 6
- New Buds 2 → max 4
- New Buds 3 → max 5
- Plass media → max 5
- Rituals 1 → max 6
- Rituals 2 → max 5
- Rituals 3 → max 6
- Rituals xl → max 4
- Tite 1 / 2 → max 6
- Tress media / piccola → max 6
- Tress mini / Stilo → max 6



Il massimo si riferisce all'installazione di lampade in composizione sfalsata. *Max refers to installation in staggered composition.*



Rosone multiplo lineare — *Linear multiple canopy*

Tress

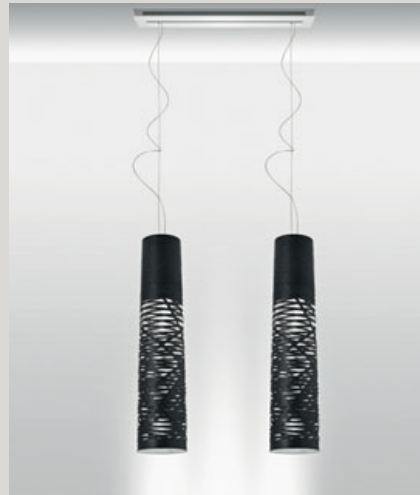

Tite 2



Rosone multiplo lineare — *Linear multiple canopy*

Maki





Rosone multiplo lineare L 135 *Linear multiple canopy L 53 5/32"*

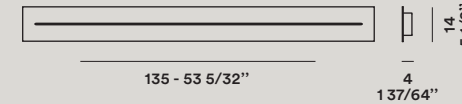

Metallo verniciato. *Laquered metal.*

- Aplomb → max 9
- Caboche piccola → max 8
- Chouchin 1 → max 6
- Chouchin 2 → max 9
- Chouchin 3 → max 8
- Chouchin mini 1 → max 6
- Chouchin mini 2 → max 9
- Gregg media → max 8
- Gregg piccola → max 9
- Havana → max 9
- Maki → max 9
- New Buds 1 → max 9
- New Buds 2 → max 8
- New Buds 3 → max 8
- Plass media → max 8
- Rituals 1 → max 9
- Rituals 2 → max 7
- Rituals 3 → max 9
- Rituals xl → max 6
- Tite 1 / 2 → max 9
- Tress media / piccola → max 9
- Tress mini / Stilo → max 9

Il massimo si riferisce all'installazione di lampade in composizione sfalsata. *Max refers to installation in staggered composition.*



Rosone multiplo lineare — *Linear multiple canopy*

Aplomb



Caboche piccola

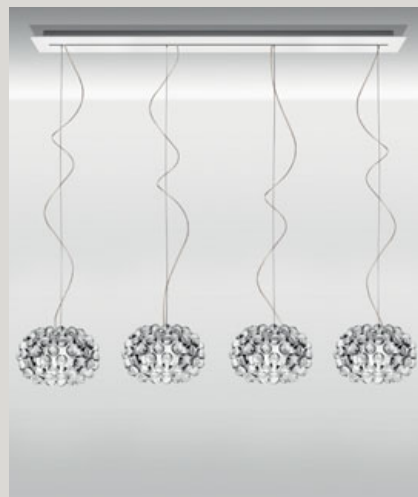

Chouchin — Chouchin mini



Gregg



Rosone multiplo lineare — *Linear multiple canopy*

Rituals



Kit decentramento Decentralization kit



Kit B

Decentramento per funi d'acciaio.
Decentralization for steel cable supports.

Per i modelli — *For the models:* Allegretto, Allegro, Behive, Big Bang, Caboche, Chouchin, Chouchin Reverse, Chouchin mini, Gregg grande / media, Le Soleil, New Buds, O-Space, Planet, Plass, Plass media, Rituals, Rituals XL, Supernova, Tropic, Tress grande / media / piccola.

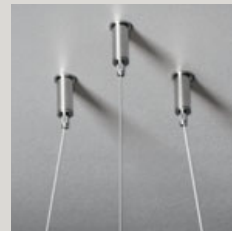

Kit C

Decentramento per cavo elettrico autoportante. *Decentralization for power cable.*



Per i modelli — *For the models:* Aplomb, Giga-Lite, Gregg piccola, Havana, Maki, Tite, Tress mini, Tress stilo, Twiggy.

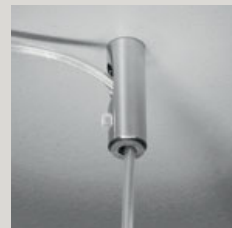

Kit F

Decentramento per funi acciaio con rosone, comprende 3 reggifuni e un rosone bianco.
Decentralization for steel cables includes 3 steel cable supports and a white canopy.



Per i modelli — *For the models:* Allegretto, Allegro, Behive, Big Bang (LED version excluded), Caboche (LED version excluded), Chouchin, Chouchin Reverse, Chouchin mini, Gregg grande / media, Le Soleil, New Buds, O-Space, Planet, Plass, Plass media, Rituals, Supernova, Tropic, Tress grande (LED version excluded) / media / piccola.



Kit M

Rosone per decentramento elettrico, fino a 4 lampade. *Canopy electrical decentralization up to 4 lamps.*



Per i modelli — *For the models:* Aplomb, Behive, Big Bang (LED version excluded), Caboche (esclusa versione LED), Chouchin, Chouchin Reverse, Chouchin mini, Giga-Lite, Gregg, Havana, Jamaica, Le Soleil, Maki, New Buds, O-Space, Planet, Plass, Plass media, Rituals, Rituals XL, Supernova, Tite, Tress (LED version excluded), Tress Stilo, Troag, Tropic, Twiggy, Wave.



Soffitto — *Ceiling*

- | | | | |
|-----|-------------------|-----|------------------------------|
| 230 | Bahia | 248 | Folio |
| 232 | Bahia mini | 250 | Gregg |
| 234 | Big Bang | 252 | Lumiere
xxl + xxs |
| 236 | Birdie | 254 | Nuage |
| 238 | Blob S | 256 | Rituals |
| 240 | Caboche | 258 | Tivu |
| 242 | Circus | 260 | Twiggy |
| 244 | Ellepi | | |
| 246 | Falena | | |

Bahia

Paolo Lucidi e Luca Pevere, 2010

LED



10 - 4"



76 - 29 7/8"

70 - 27 3/4"

Polycarbonato stampato a iniezione.
Injection moulded polycarbonate.

LED 43W 2850°K 4210 lm included
Dimmerabile — *Dimmable*

220 / 240 / 120V: fluo 1x40W + 1x22W 2GX13
Energy class A+, A

⚡ IP 20 —  (LED)

Bianco. *White.*



collection →



p. 232 p. 272 p. 274



Bahia mini

Paolo Lucidi e Luca Pevere, 2015

LED



53 - 20 7/8"

Policarbonato stampato a iniezione.
Injection moulded polycarbonate.

LED 21,5W 2850°K 2105 lm included
Dimmerabile — *Dimmable*

220 / 240 / 120V: fluo 1x22W 2GX13
Dimmable version available
Energy class A+, A



Bianco. *White.*



collection →

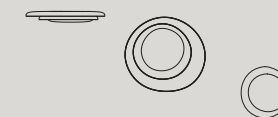

p. 230 p. 272 p. 274



Big Bang

Enrico Franzolini con Vicente Garcia Jimenez, 2006



23 - 9"

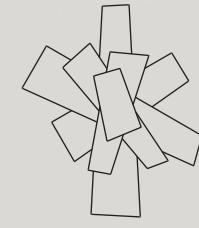

66 - 26"

79 - 31"

Metacrilato e metallo laccato.
Methacrylate and lacquered metal.

220 / 240V: halo 1x120W R7s
120V: halo 1x100W RSC
Energy class C

 IP 20

Bianco, rosso.
White, red.

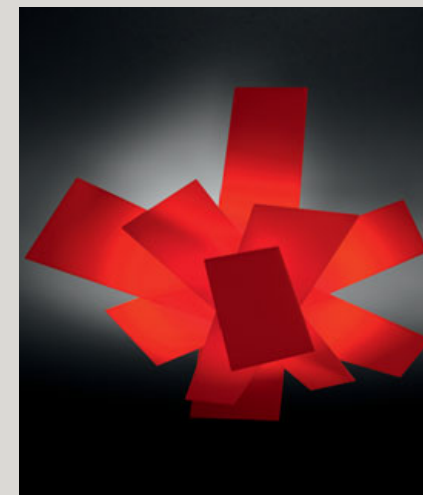

collection →

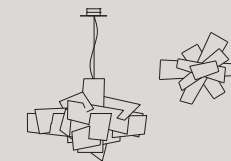

p. 146

p. 276



Birdie

Ludovica e Roberto Palomba, 2012



Polycarbonato e alluminio verniciato.
Polycarbonate and varnished aluminium.

LED E27/E26

220 / 240V: halo 1-3-6-9x70W E27,
fluo 1-3-6-9x20W E27
120V: 1-3-6-9x60W E26,
fluo 1-3-6-9x20W E26
Energy class A+, A, B, C

Altezze differenti a richiesta — Different heights on request



Bianco, grigio, arancio, amaranto.
White, gray, orange, amaranth.



Birdie 1

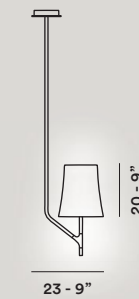

Birdie 3

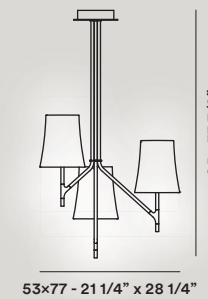

Birdie 6

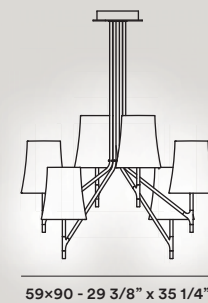

Birdie 9

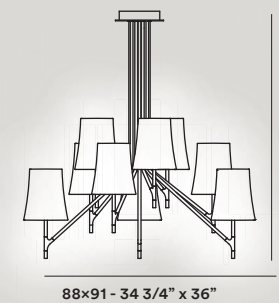

← Birdie 6 e 9 disponibile anche a sospensione — Birdie 6 and Birdie 9 suspension version available.

collection →

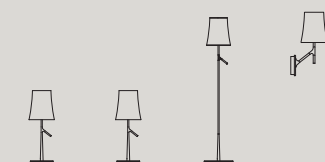

p. 026 p. 028 p. 074 p. 278



Blob s

Karim Rashid, 2002

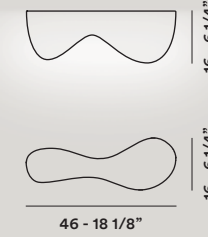

Polietilene stampato a rotazione e metallo verniciato.
Rotational moulded polyethylene and varnished metal.

220 / 240 / 120V: fluo 1x24W 2G11
Energy class A+, A

☐ IP 20

Bianco. *White.*



collection →



Caboche

Patricia Urquiola con Eliana Gerotto, 2006



19 - 7 1/2"

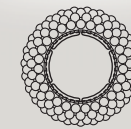

50 - 19 3/4"

Polimetilmetacrilato, vetro soffiato e metallo cromato.
PMMA, blown glass and chromed metal.

220 / 240V: halo 1x120W R7s
120V: halo 1x100W RSC
Energy class C



Trasparente, giallo oro.
Transparent, gold yellow.

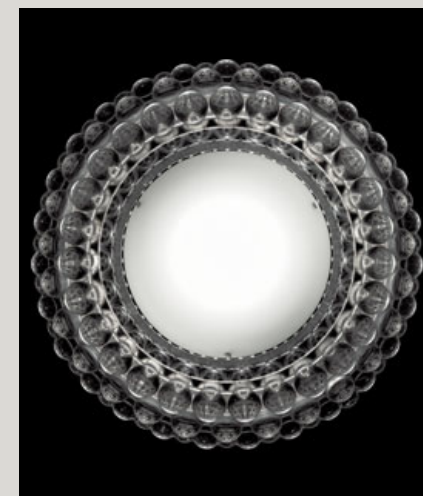

collection →

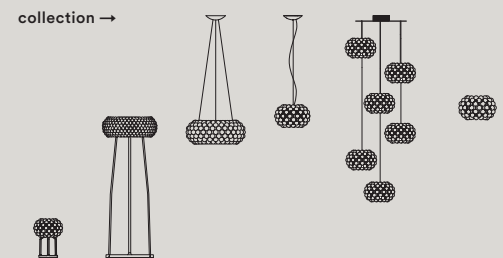

p. 030 p. 076 p. 152 p. 154 p. 214 p. 284



Circus

Defne Koz, 1994



grande



13
5 1/8"



46 - 18 1/8"

piccola



12
4 3/4"



32 - 12 5/8"

Vetro soffiato, metallo verniciato o nichelato.
Blown glass, nickelplated or varnished metal.

LED E27/E26 — E14/E12

Circus grande
220 / 240V: halo 4x46W E27,
fluo 4x12W E27
120V: inc 4x40W E26,
fluo 4x13W E26
Energy class A+, A, B, C

Circus piccola
220 / 240V: halo 4x30W E14,
fluo 4x8W E14
120V: inc 4x25W E12,
fluo 4x8W E12
Energy class A+, A, B, C



Bianco. *White.*



collection →



Ellepi

Alessandra Matilde, 2003

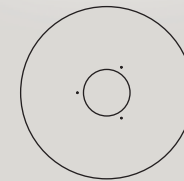

74 - 29 1/8"

Metacrilato e metallo verniciato.
Methacrylate and varnished metal.

220 / 240V: fluo 1x55W 2GX13
120V: fluo 1x40W 2GX13
Energy class A+, A

  IP 20

Bianco. *White.*



collection →



p. 290

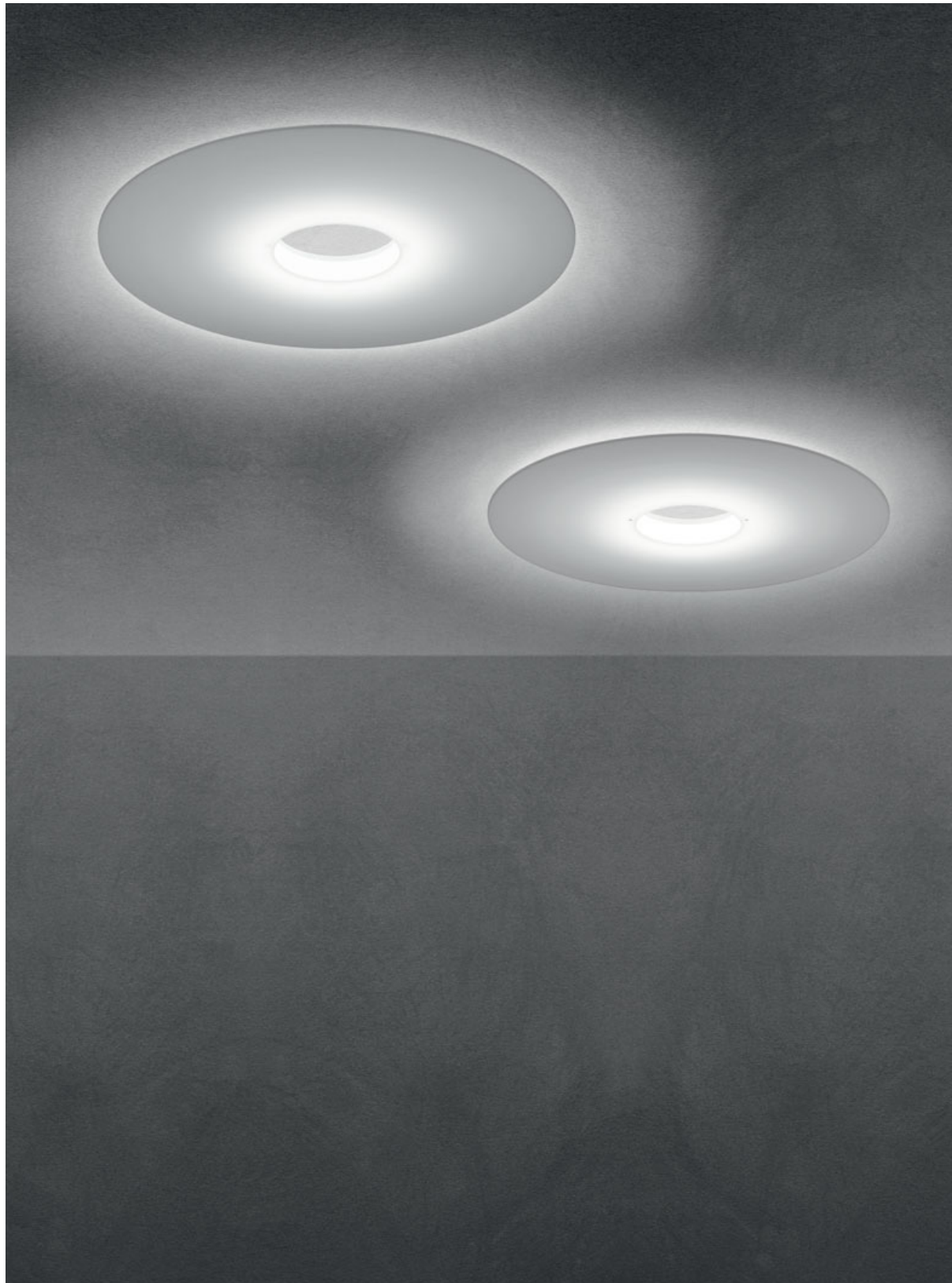

Falena

Paolo Lucidi e Luca Pevere, 2011

Falena 2

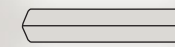

76,5 - 30 1/8" 7,5 2 7/8"

Falena 3



136,5 - 53 3/4" 7,5 2 7/8"

Alluminio verniciato e policarbonato.
Varnished aluminium and polycarbonate.

Falena 2
220 / 240 / 120V: fluo 1x24W G5
Energy class A+, A

Falena 3
220 / 240 / 120V: fluo 1x54W G5
Energy class A+, A



Bianco. *White.*



collection →



Folio

Carlo Urbinati e Alessandro Vecchiato, 1990



10
3 7/8"

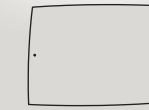

38 - 15"

48 - 18 7/8"

Vetro soffiato satinato e metallo laccato.
Blown acid-etched glass and varnished metal.

220 / 240V: halo 1x120W R7s,
fluo 2x24W 2G11
120V: halo 1x100W RSC,
fluo 2x24W 2G11
Energy class A+, A, C



Bianco. *White.*



collection →



Gregg

Ludovica e Roberto Palomba, 2007



Gregg media

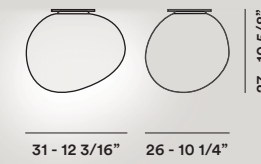

Gregg piccola

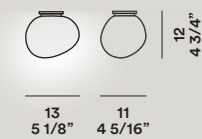

Vetro soffiato acidato e metallo verniciato.
Blown acid-etched glass and white lacquered metal.

Gregg media
LED E27/E26

220 / 240V: halo 1x150W E27,
fluo 1x25W E27
120V: halo 1x100W E26,
fluo 1x26W E26
Energy class A+, A, B, C

Gregg piccola
220 / 240V: halo 1x20W G9
120V: halo 1x25W G9
Energy class C



Bianco. *White.*



collection →

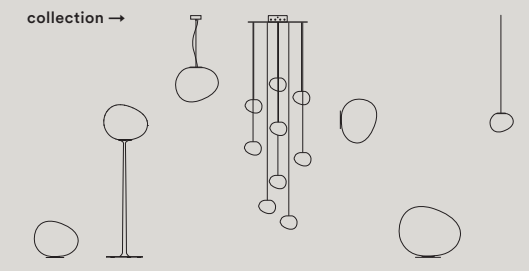

p. 036 p. 082 p. 164 p. 214 p. 304 p. 332 p. 330



Lumiere xxl + xxs

Rodolfo Dordoni, 2010



Lumiere xxl



13
5 1/4"

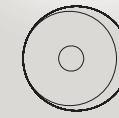

34 - 13 3/8"

Lumiere xxs



10
4 1/8"



25 - 9 5/8"

Vetro soffiato e metallo laccato.
Blown glass and lacquered metal.

Lumiere xxl
220 / 240V: fluo 1x40W + 1x22W 2GX13,
fluo 1x55W dimmerabile *dimnable* 2GX13
120V: fluo 1x40W 2GX13
Energy class A+, A

Lumiere xxs
220 / 240V: fluo 2x18W G24q-2
120V: fluo 2x18W G24q-2
Energy class A+, A



Bianco. *White.*



collection →



p. 046

p. 316

Nuage

Philippe Nigro, 2012

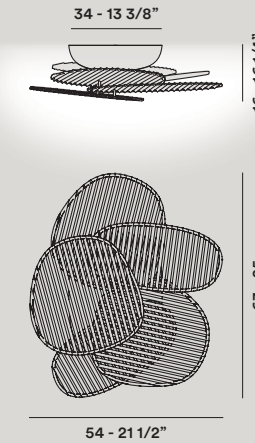

Policarbonato stampato a iniezione e ABS masterizzato.
Injection-moulded polycarbonate and batch-dyed ABS.

Utilizzabile in composizione — *Usable in composition*

220 / 240V: fluo 1x40W + 1x22W 2GX13
fluo 1x55W dimmerabile *dimnable* 2GX13
120V: fluo 1x40W
Energy class A+, A

Dimmerabile — *Dimmable*



Bianco, verde, rosso.
White, green, red.



collection →

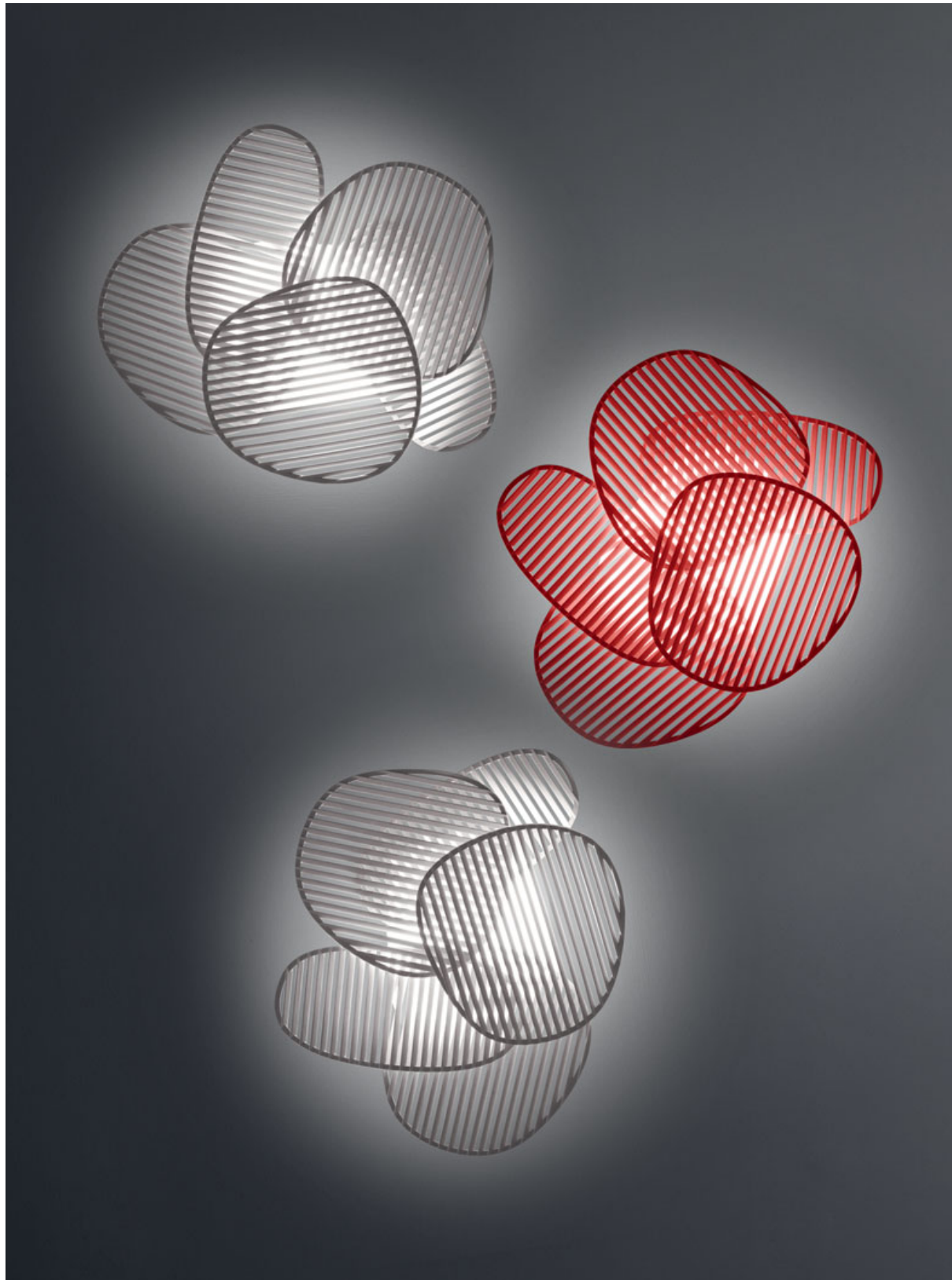
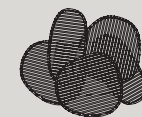

Rituals

Ludovica e Roberto Palomba, 2015

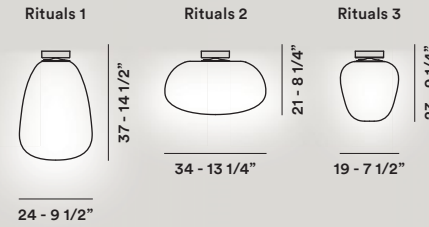

Vetro soffiato satinato inciso e metallo verniciato.
Blown engraved satin glass and lacquered metal.

LED E27/E26

220 / 240V: halo 1x70W E27,
fluo 1x15W E27
120V: halo 1x70W E26,
fluo 1x15W E26
Energy class A+, A, B, C



Bianco. *White.*



collection →

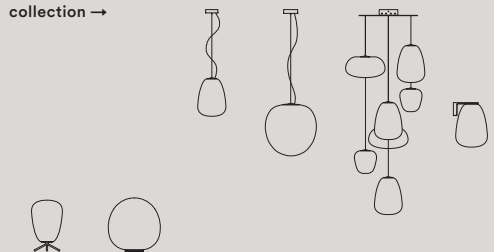

p. 058 p. 060 p. 186 p. 188 p. 214 p. 320

Tivu

Joseph Forakis, 2011

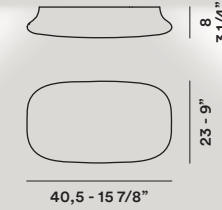

Policarbonato stampato a iniezione.
Injection moulded polycarbonate.

220 / 240 / 120V: fluo 2x18W 2G11
Energy class A+, A



Bianco, nero.
White, black.



collection →



Twiggy

Marc Sadler, 2007

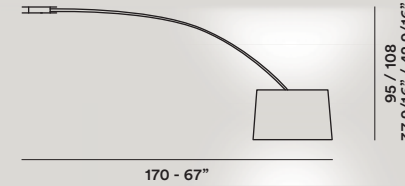

Materiale composito su base di fibra di vetro verniciato, policarbonato, PMMA e metallo verniciato.
Coated fibreglass based composite material, PMMA, polycarbonate and varnished metal.

LED E27/E26

220 / 240V: halo 3x77W E27,
fluo 3x20W E27
120V: inc 3x100W E26,
fluo 3x20W E26
Energy class A+, A, B, C

Girevole a 360° — Rotating 360°



Bianco, nero.
White, black.

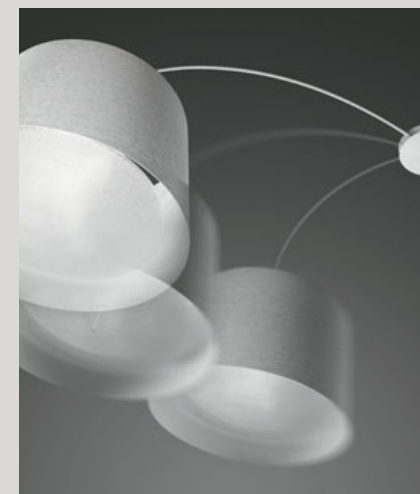

collection →

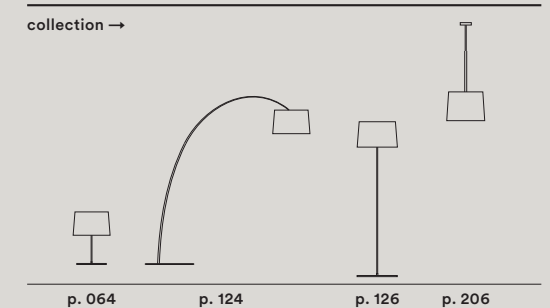

Parete — Wall

- | | | | |
|-----|-------------------|-----|-------------------|
| 264 | Aplomb | 302 | Folio |
| 266 | Bahia | 304 | Gregg |
| 274 | Bahia mini | 306 | Havana |
| 276 | Big Bang | 308 | Innerlight |
| 278 | Birdie | 310 | Kite |
| 280 | Bit | 312 | Lake |
| 282 | Blob s | 314 | Le Soleil |
| 284 | Caboche | 316 | Lumiere |
| 286 | Circus | | xxl + xxs |
| 288 | Double | 318 | Nuage |
| 290 | Ellepi | 320 | Rituals |
| 292 | Falena | 322 | Tivu |
| 294 | Fields | 324 | Tress |
| 300 | Flip | 326 | Tutù |



Aplomb

Paolo Lucidi e Luca Pevere, 2014



30 - 11 3/4"



15 - 6"

24
9 1/2"

Cemento, metallo verniciato e alluminio.
Concrete, varnished metal and aluminium.

LED 13W 2700°K 1120 lm included
Energy class A+

*Dimmable only with SEOUL-ACRICH LED
modules dimmer*

⊕ ⚡ IP 20

Bianco, grigio cemento, marrone.
White, concrete grey, brown.



collection →

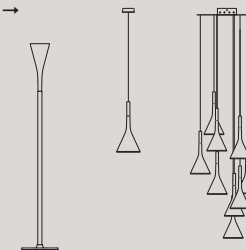

p. 072

p. 138

p. 214

Lampada da parete e soffitto — *Wall and ceiling lamp*

Bahia

Paolo Lucidi e Luca Pevere, 2010

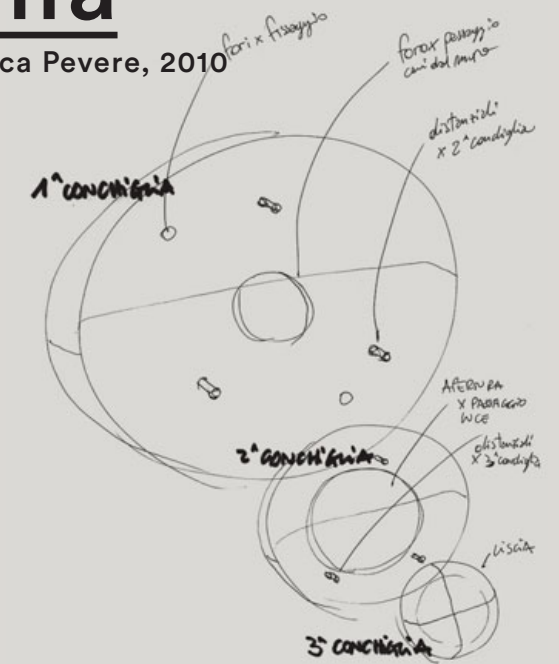

Bahia, affascinante eleganza. Illuminare ed al tempo stesso arredare un ambiente, con una presenza morbida, poetica e infinitamente affascinante: questa è la seducente promessa di Bahia. Un'armonia di luci e ombre, generata dalla semplice sovrapposizione di tre diffusori, disposti seguendo una studiata asimmetria ed alternanza di superfici concave e convesse, in una forma che ricorda un'isola vista dall'alto.

Bahia, charming elegance. Lighting while at the same time decorating a setting, with a soft, poetic and infinitely charming presence: this is the seductive promise made by Bahia. A harmony of lights and shadows generated by the simple overlapping of three diffusers, arranged according to a purpose-devised asymmetry and alternating concave and convex surfaces, in a shape that recalls an island seen from above.

Poetic

Bahia — Paolo Lucidi e Luca Pevere, 2010

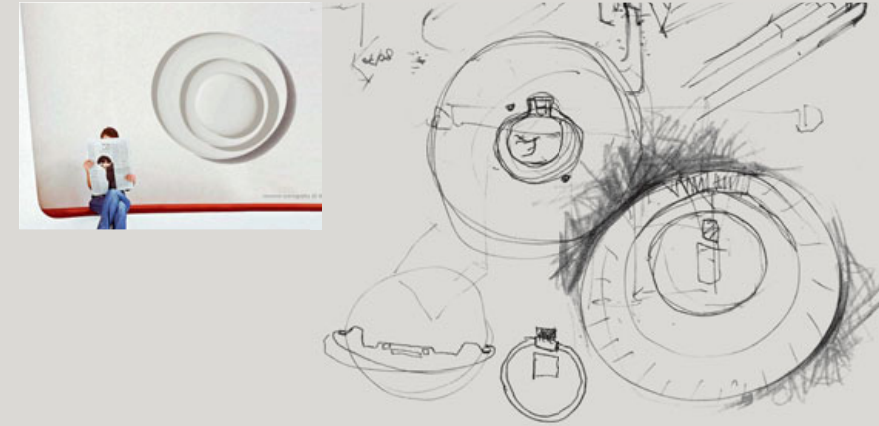
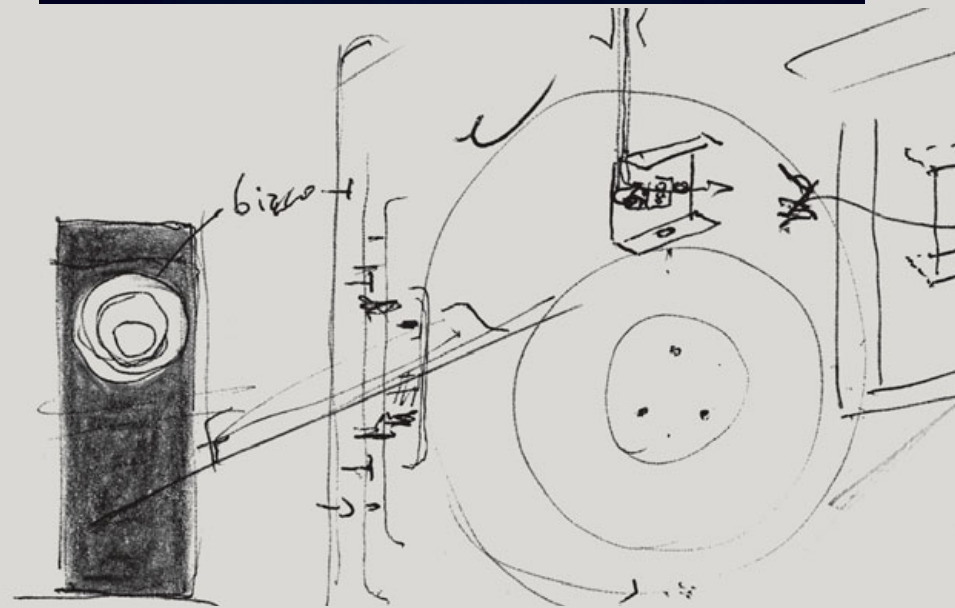

Completamente bianca, pura ed assoluta, capace di coprire un'area ampia ma con uno spessore minimo, Bahia assume una sensazionale profondità visiva, grazie ai bagliori concentrici che emanano da essa, riflettendosi sulla parete e diffondendosi nello spazio circostante.

Completely white, pure and absolute, capable of covering a large surface yet with a minimal thickness, Bahia assumes a sensational visual depth, thanks to the concentric glows it casts, which are reflected on the wall and diffused into the surroundings.

Reflections

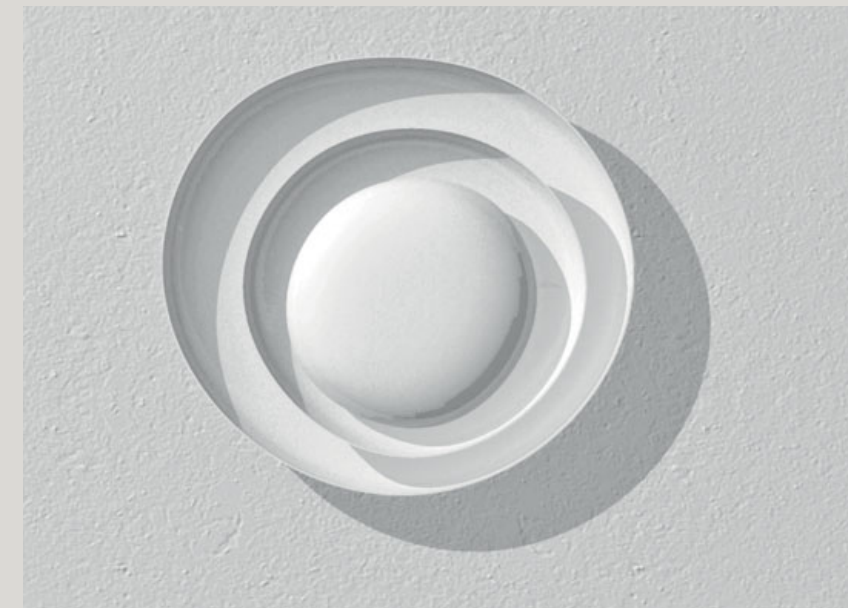

Bahia — Paolo Lucidi e Luca Pevere, 2010

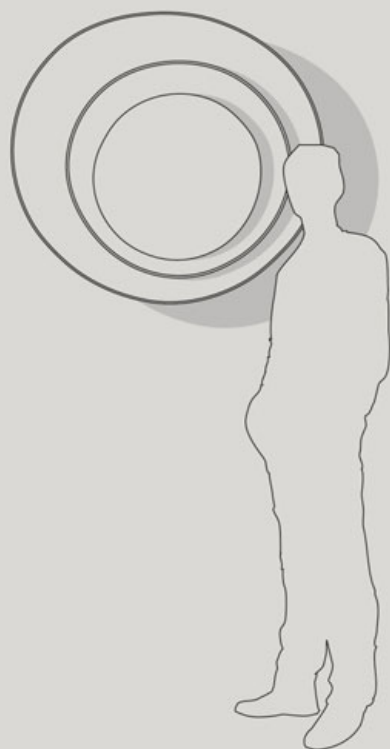

Da sola o in composizioni multiple, anche con orientamenti diversi per creare giochi grafici, Bahia diffonde in qualsiasi spazio un'originale emozione e un'affascinante illuminazione.

Used alone or in multiple compositions, also pointing in different directions to create graphic games, Bahia creates an original feel by casting a charming light into any room.

Textes en francais, Deutsche Texte, Textos en espanol → p. 343

Compositions

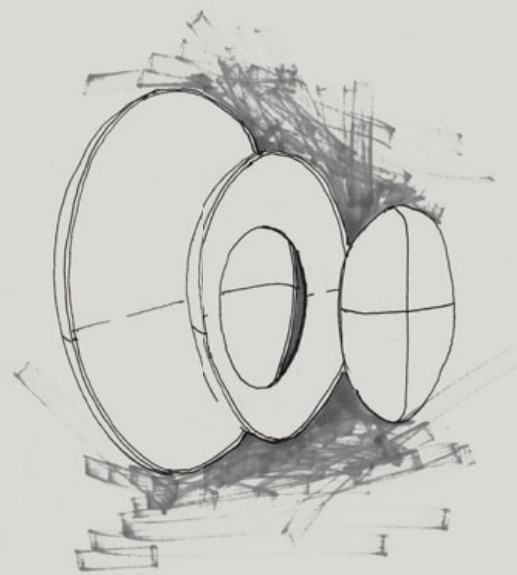

Bahia

Paolo Lucidi e Luca Pevere, 2010

LED

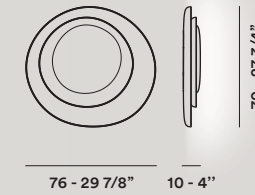

Polycarbonato stampato a iniezione.
Injection moulded polycarbonate.

LED 43W 2850°K 4210 lm included
Dimmerabile — *Dimmable*

220 / 240 / 120V: fluo 1x40W + 1x22W 2GX13
Energy class A+, A

⊕ ⚡ IP 20 ADA — cULus (LED)

Bianco. *White.*



collection →



p. 230 p. 232 p. 274



Bahia mini

Paolo Lucidi e Luca Pevere, 2015

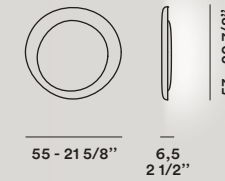

Policarbonato stampato a iniezione.
Injection moulded polycarbonate.

LED 21,5W 2850°K 2105 lm included
Dimmerabile — *Dimmable*

220 / 240 / 120V: fluo 1x22W 2GX13
Dimmable version available
Energy class A+, A



Bianco. *White.*



collection →



Big Bang

Enrico Franzolini con Vicente Garcia Jimenez, 2006

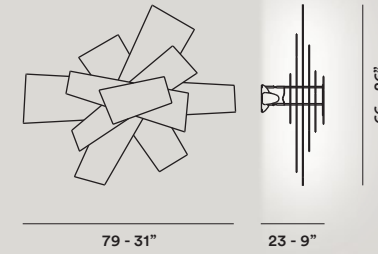

Metacrilato e metallo laccato.
Methacrylate and lacquered metal.

220 / 240V: halo 1x120W R7s
120V: halo 1x100W RSC
Energy class C



Bianco, rosso.
White, red.



collection →

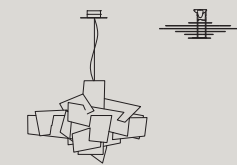

p. 146

p. 234

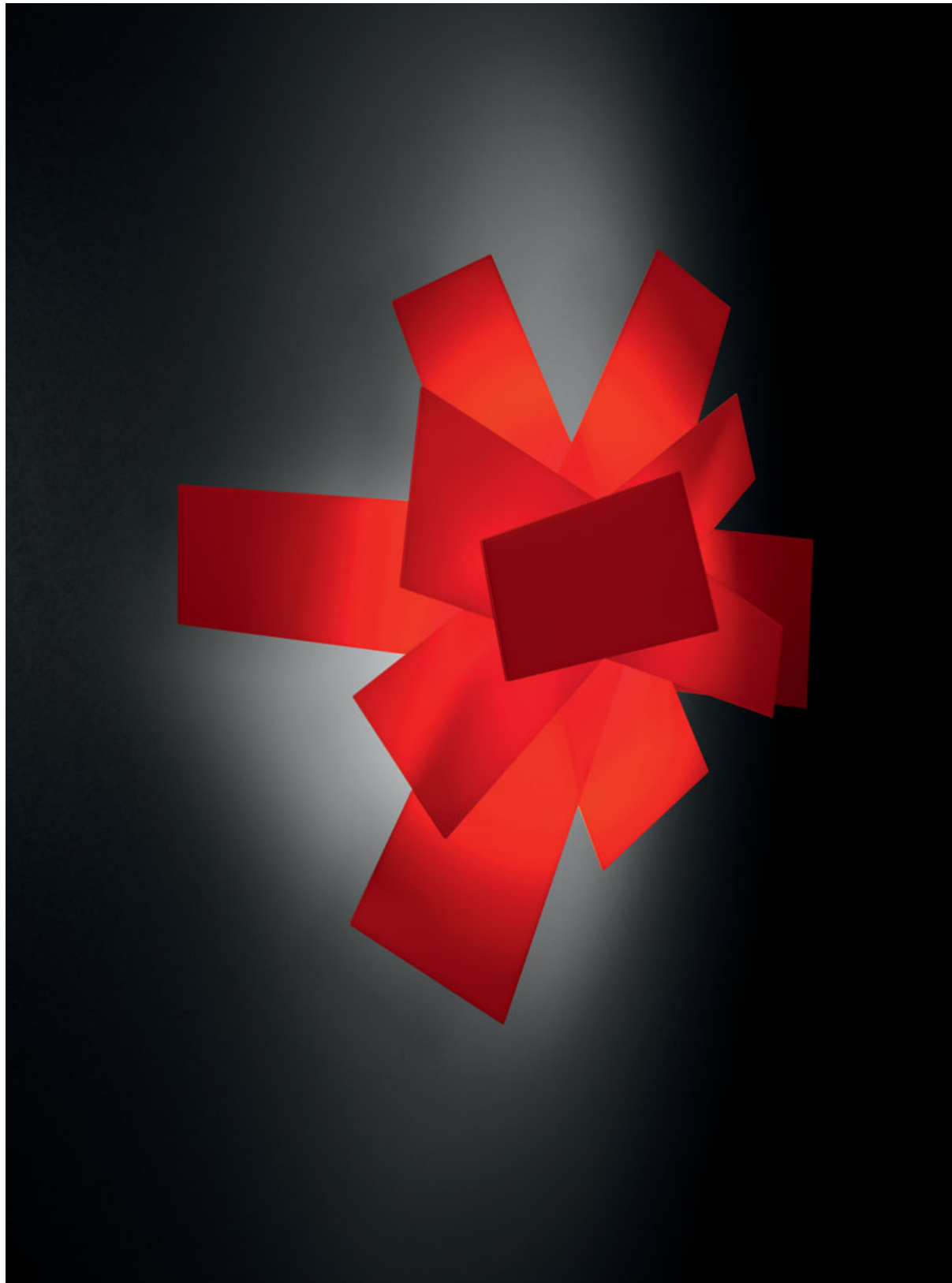

Birdie

Ludovica e Roberto Palomba, 2012



17 - 6 3/4"

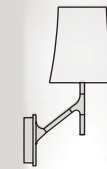

42 - 16 3/4"

24 - 9 1/2"

Policarbonato, acciaio e metallo verniciato.
Polycarbonate, varnished steel and metal.

LED E27/E26

**220 / 240V: halo 1x70W E27,
fluo 1x25W E27**

220/240V touch dimmer version available

**120V: halo 1x60W E26,
fluo 1x20W E26**

Energy class A+, A, B, C



Bianco, grigio, arancio, amaranto.
White, grey, orange, amaranth.



collection →

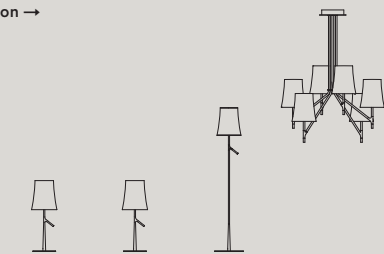

p. 026

p. 028

p. 074

p. 236



Bit

Ferruccio Laviani, 1993



Bit 1



Bit 2



Bit 3



Bit 4



Bit 5

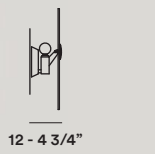

Vetro serigrafato e metallo verniciato.
Silkscreen-printed glass and lacquered metal.

LED E14/E12

220 / 240V: halo 1x46W E14,
fluo 1x12W E14
120V: inc 1x60W E12,
fluo 1x13W E12
Energy class A+, A, B, C



Bianco, colorato (1 rosso, 2 blu, 4 verde, 5 arancio).
White, colored (1 red, 2 blue, 4 green, 5 orange).

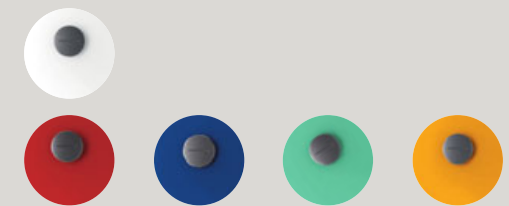

collection →



Blob s

Karim Rashid, 1993

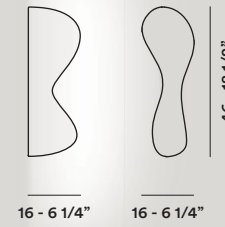

Polietilene stampato a rotazione e metallo verniciato.
Rotational moulded polyethylene and varnished metal.

220 / 240 / 120V: fluo 1x24W 2G11
Energy class A+, A

☐ IP 20

Bianco. *White.*



collection →



Caboche

Patricia Urquiola con Eliana Gerotto, 2006

media

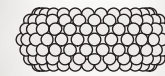

50 - 19 3/4"



24,5 - 9 5/8"

19,5 - 7 3/5"

piccola



31 - 12 1/5"



18 - 7"

19,5 - 7 3/5"

Polimetilmetacrilato, vetro soffiato e metallo cromato.
PMMA, blown glass and chromed metal.

220 / 240V: halo 1x120W R7s
120V: halo 1x100W RSC
Energy class C



Trasparente, giallo oro.
Transparent, gold yellow.



collection →

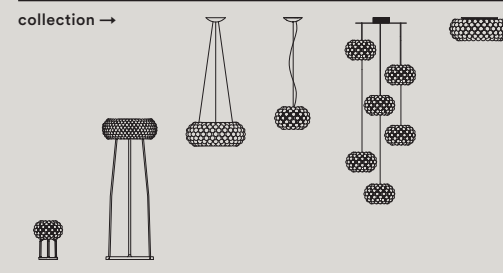

p. 030 p. 076 p. 152 p. 154 p. 214 p. 240



Circus

Defne Koz, 1994



Circus grande

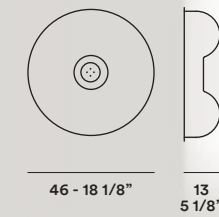

46 - 18 1/8"

13
5 1/8"

Circus piccola

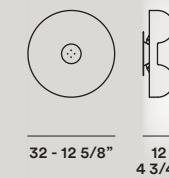

32 - 12 5/8"

12
4 3/4"

Vetro soffiato, metallo verniciato o nichelato.
Blown glass, nickelplated or varnished metal.

LED E27/E26 — E14/E12

Circus grande
220 / 240V: halo 4x46W E27,
fluo 4x12W E27
120V: inc 4x40W E26,
fluo 4x13W E26
Energy class A+, A, B, C

Circus piccola
220 / 240V: halo 4x30W E14,
fluo 4x8W E14
120V: inc 4x40W E12,
fluo 4x8W E12
Energy class A+, A, B, C

   IP 20

Bianco. *White.*



collection →

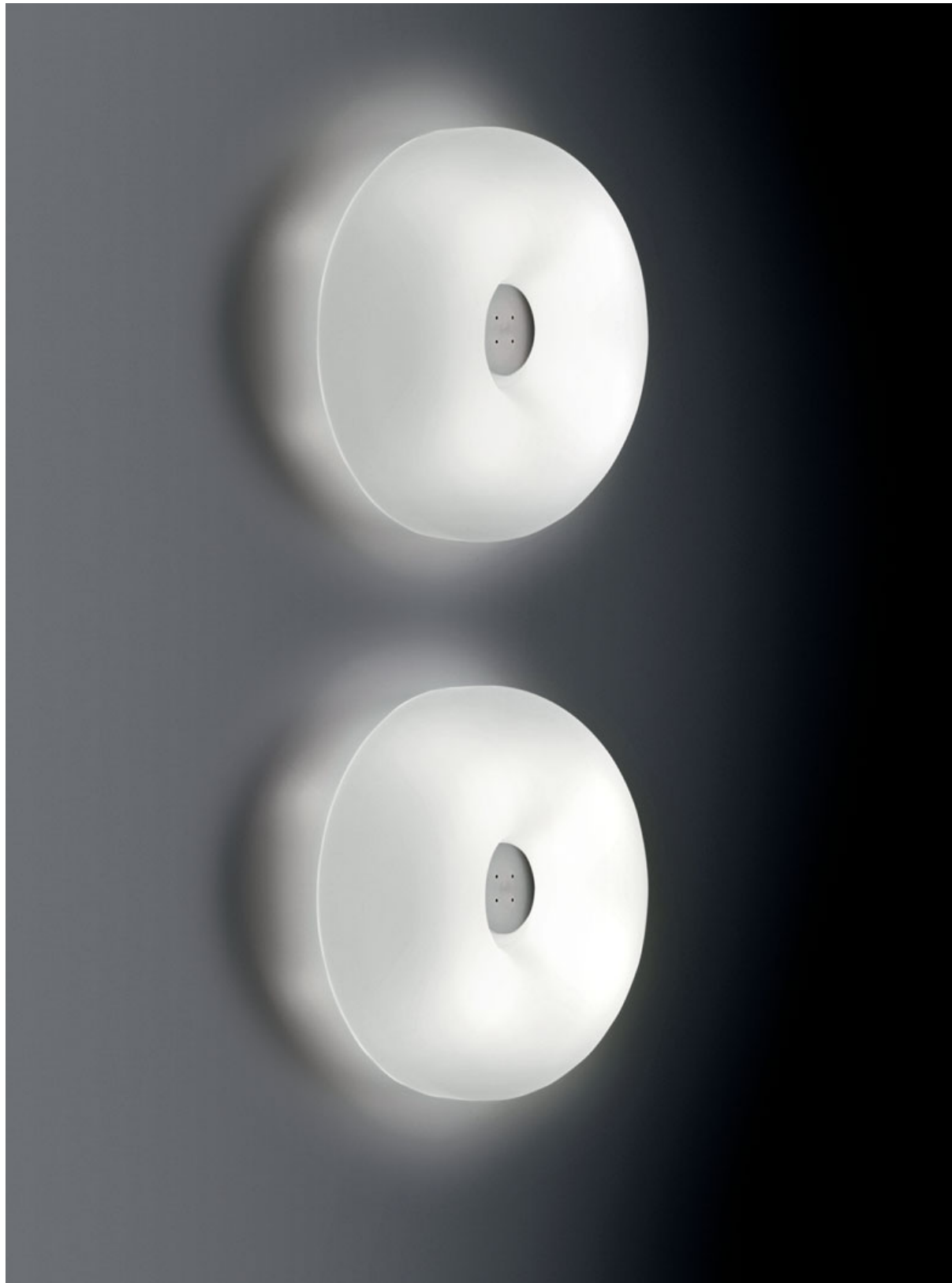

Double

Valerio Bottin, 1996

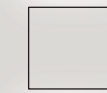

26 - 10 1/4"

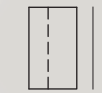

13 - 5 1/2"

24 - 9 1/2"

Vetro soffiato e metallo verniciato.
Blown glass and varnished metal.

LED E27/E26

220 / 240V: halo 2x77W E27,
fluo 2x20W E27

120V: inc 2x100W E26,
fluo 2x20W E26

Energy class A+, A, B, C



Bianco, avorio.
White, ivory.



Ellepi

Alessandra Matilde, 2003

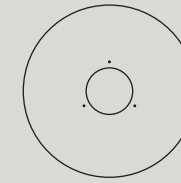

74 - 29 1/8"



6,5
2 1/2"

Metacrilato e metallo verniciato.
Methacrylate and varnished metal.

220 / 240V: fluo 1x55W 2GX13

120V: fluo 1x40W 2GX13

Energy class A+, A



Bianco. *White.*

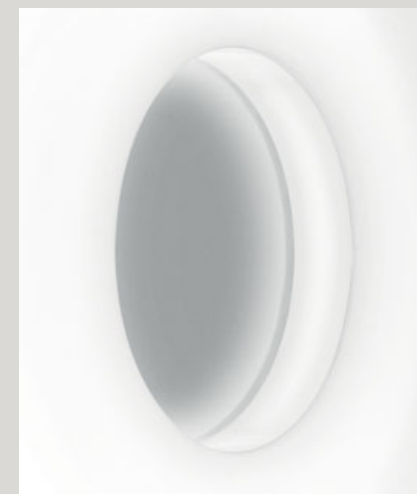

collection →



Falena

Paolo Lucidi e Luca Pevere, 2011



Falena 1



22
8 5/8"

9
3 1/2"

Falena 2

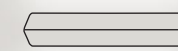
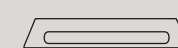

76,5 - 30 1/8"

9
3 1/2"

Falena 3

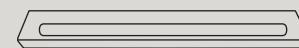

136,5 - 53 3/4"

9
3 1/2"

Alluminio verniciato e policarbonato.
Varnished aluminium and polycarbonate.

Anche uso in verticale Falena 2/3
— Falena 2 / 3 Horizontal and vertical use

Falena 1
220 / 240V: halo 1x80W R7s
120V: halo 1x100W RSC
Energy class C

Falena 2
220 / 240 / 120V: fluo 1x24W G5
Energy class A+, A

Falena 3
220 / 240 / 120V: fluo 1x54W G5
Energy class A+, A

220 / 240V falena 2 / 3
dimmerabile — dimmable



Bianco. White.



collection →



Lampada da parete — *Wall lamp*

Fields

Vicente Garcia Jimenez, 2007

Fields, geometrie infinite. Un progetto che prende spunto dall'immagine di una pianura suddivisa in campi coltivati, vista da un finestrino d'aereo, per creare un sistema di illuminazione da parete versatile, originale, caratterizzante.

Fields, endless geometries. This project draws its inspiration from a plain split up into cultivated fields, seen from an airplane window, to create a versatile, original, and distinguishing lighting system.

Landscape

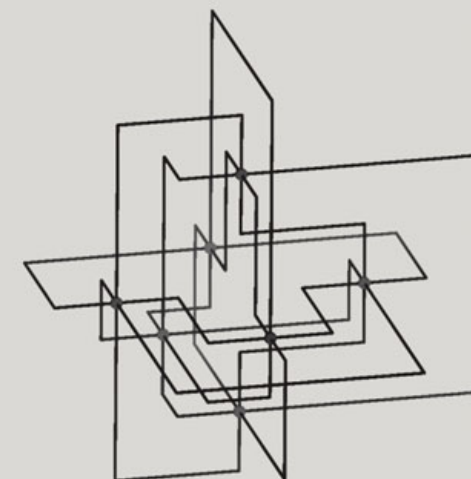

Fields — Vicente Garcia Jimenez, 2007



Un'idea che nasce dall'osservazione della natura e prende forma attraverso un uso creativo della geometria e della tecnologia. Un segno grafico discreto, oppure una composizione importante: Fields permette di realizzare qualsiasi soluzione, partendo da tre elementi di base, utilizzabili da soli o in gruppo.



This idea stems from observing nature and has taken shape through the creative use of geometry and technology. A discreet graphic mark, or a significant composition: Fields makes it possible to achieve any solution, starting with three basic elements, which can be used on their own or in groups.



Infinite

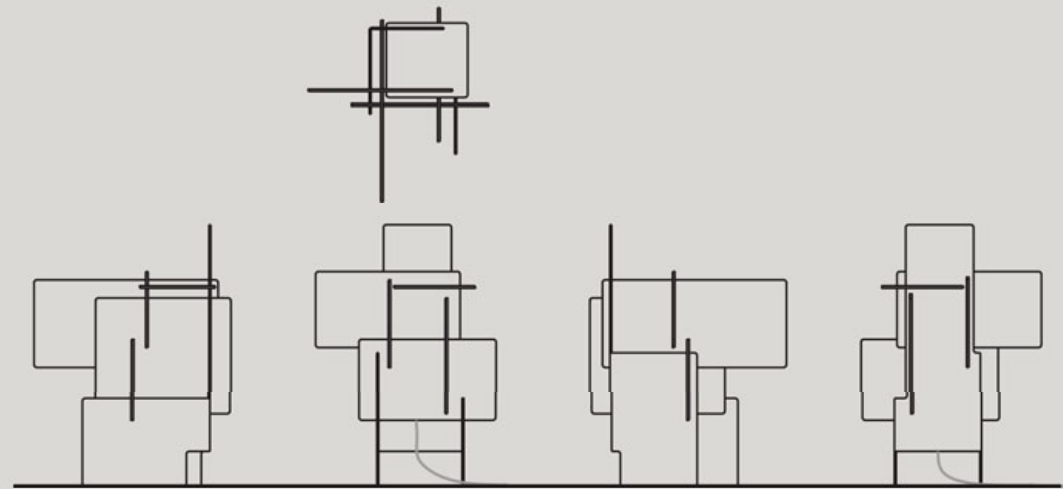

Sovrapponendosi e intersecandosi, lastre rettangolari di metacrilato semitrasparente e alluminio laccato aggiungono alla piatta superficie della parete un'inedita dimensionalità di luci, riflessi, ombre e colori: dal bianco puro e scultoreo, alla solarità del rosso e dell'arancio.

By overlapping them and arranging them in a criss-cross pattern, rectangular slabs of semi-transparent methacrylate and lacquered aluminium add an unprecedented dimension to the flat wall surface, affording lights, reflections, shadows and colours: from pure sculptural white, to sunny shades of red and orange.

Textes en francais, Deutsche Texte, Textos en espanol → p. 343

Compositions

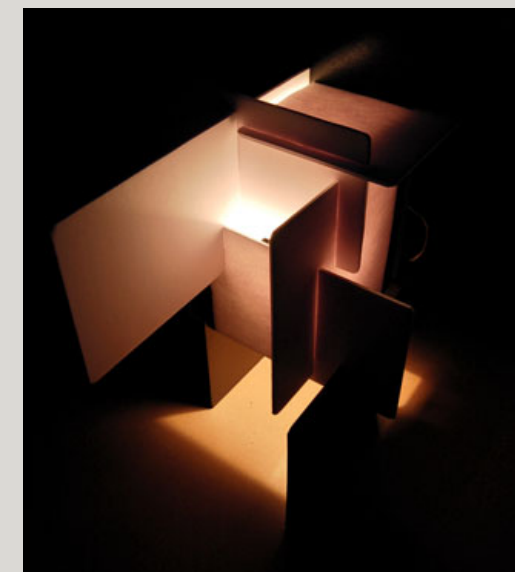
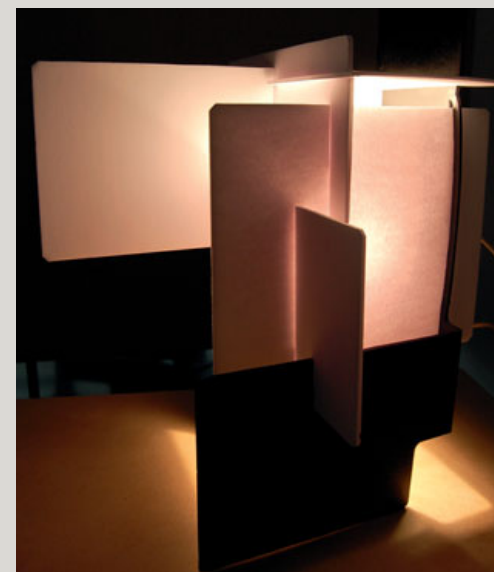

Fields

Vicente Garcia Jimenez, 2007

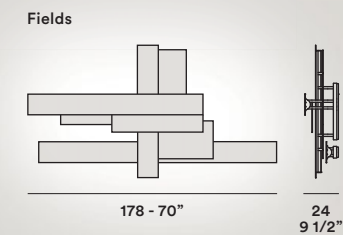
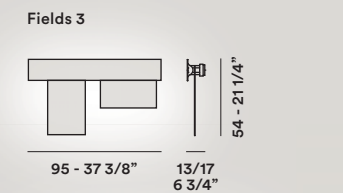
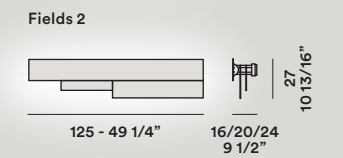
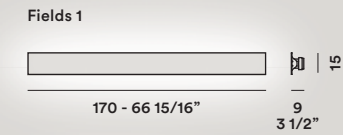

Metacrilato, alluminio verniciato e policarbonato.
Methacrylate, varnished aluminium and polycarbonate.

Anche uso in verticale — *Horizontal and vertical use*

Fields 1
220 / 240 / 120V: fluo 1x80W G5
Energy class A+, A

Fields 2
220 / 240 / 120V: fluo 1x54W G5
Energy class A+, A

Fields 3
220 / 240 / 120V: fluo 1x39W G5
Energy class A+, A

Fields
220 / 240 / 120V: fluo 1x80W G5 + 1x54W G5 + 1x39W G5
Energy class A+, A

IP 20 — (Fields 1)

Bianco, arancio.
White, orange.

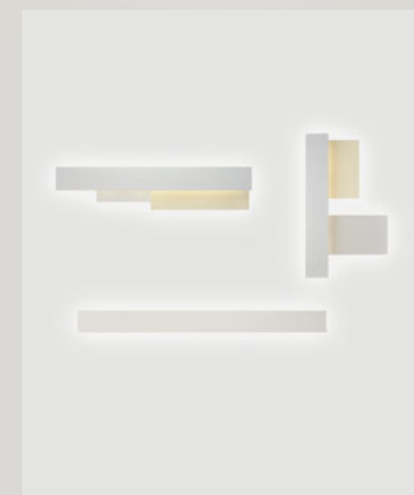



Flip

Simon Pengelly, 2013

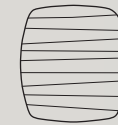

28 - 11"

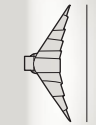



13
5 1/8"

Policarbonato verniciato stampato a iniezione e metallo verniciato o alluminio (LED).
Injection moulded varnished polycarbonate and varnished metal or aluminium (LED).

LED 16W 3000°K 1200 lm included
Energy class A

Dimmable only with SEOUL-ACRICH LED modules dimmer

220 / 240V: halo 1x120W R7s
120V: halo 1x100W RSC
Energy class C

  IP 20 —  (halo)

Bianco. *White.*



Folio

Carlo Urbinati e Alessandro Vecchiato, 1990

Vetro soffiato satinato e metallo laccato.
Blown acid-etched glass and varnished metal.

Folio grande
220 / 240V: halo 1x120W R7s,
fluo 2x24W 2G11
120V: halo 1x150W RSC,
fluo 2x24W 2G11
Energy class A+, A, C

Folio piccola
220 / 240V: halo 1x120W R7s,
fluo 2x18W 2G11
120V: halo 1x150W RSC,
fluo 2x18W 2G11
Energy class A+, A, C

   IP 20 

Bianco. *White.*



Folio grande

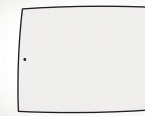

48 - 18 7/8"



10
3 7/8"

38 - 15"

Folio piccola

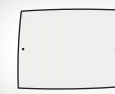

33 - 13"



8
3 1/8"

25 - 9 5/6"



collection →



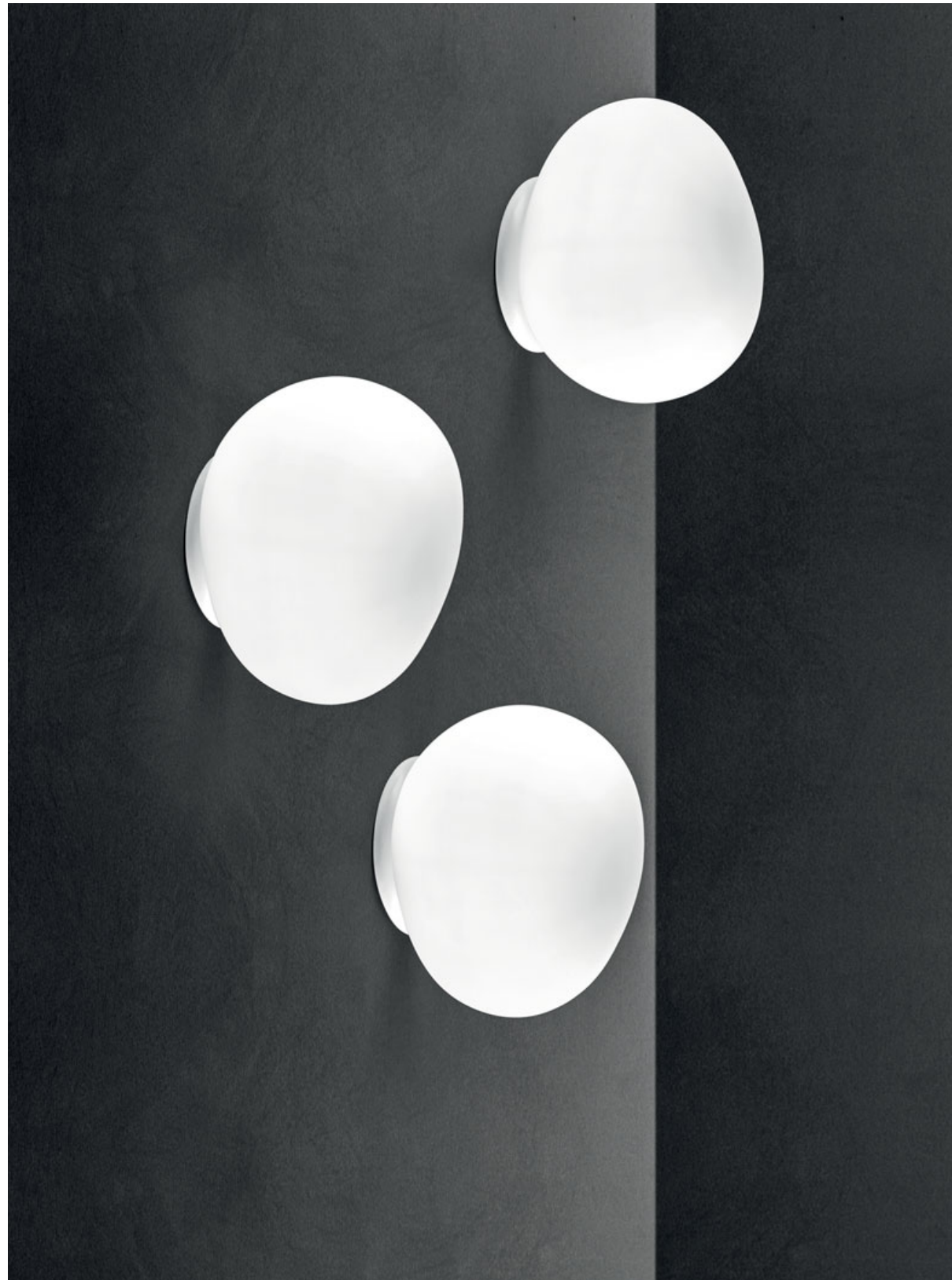

Gregg

Ludovica e Roberto Palomba, 2007



Gregg media

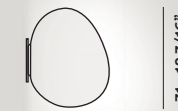

27 - 10 5/8"

Gregg piccola



12 4 3/4"

Vetro soffiato satinato, metallo verniciato.
Blown acid-etched glass and varnished metal.

Gregg media
LED E27/E26

220 / 240V: halo 1x150W E27,
fluo 1x25W E27
120V: halo 1x100W E26,
fluo 1x26W E26
Energy class A+, A, B, C

Gregg piccola
220 / 240V: halo 1x20W G9
120V: halo 1x25W G9
Energy class C



Bianco. *White.*



collection →

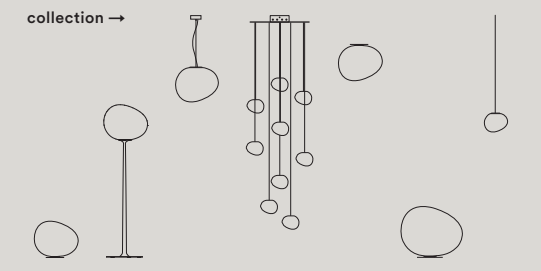

p. 036 p. 082 p. 164 p. 214 p. 250 p. 332 p. 330



Havana

Jozeph Forakis, 1993

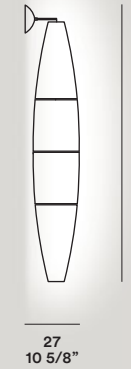

Polietilene stampato a iniezione e metallo verniciato.
Injection moulded polyethylene and varnished metal.

LED E27/E26

220 / 240V: halo 1x116W E27,
 fluo 1x25W E27
 120V: inc 1x100W E26,
 fluo 1x26W E26
Energy class A+, A, B, C



Bianco. *White.*



collection →

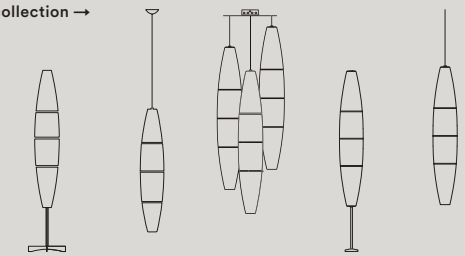

p. 088

p. 166

p. 214

p. 336

p. 334

Innerlight

Simon Pengelly, 2012



77 - 30 1/4"



32 - 12 1/2"

11
4 1/2"

Policarbonato traslucido e acciaio verniciato o acidato e spazzolato.
Translucent polycarbonate and varnished or acid-etched steel.

220 / 240 / 120V: fluo 2x36W 2G11
Energy class A+, A

220 / 240V dimmerabile — *dimnable*

   IP 20

Bianco, marrone.
White, brown.



Kite

Marc Sadler, 2003



6 1/3"



42 - 16 1/2"

27 - 10 5/8"

Tessuto di vetro con fibra di carbonio e metallo verniciato.
Fiber glass fabric with carbonium thread and varnished metal.

LED E27/E26

220 / 240V: halo 3x30W E14, fluo 3x8W E14
120V: inc 3x40W E12, fluo 3x8W E12
Energy class A+, A, B, C



Nero. Black.



collection →

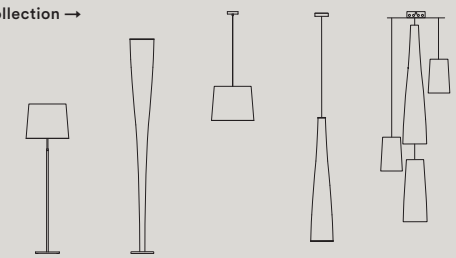

p. 080

p. 100

p. 162

p. 194

p. 214



Lake

Paolo Lucidi e Luca Pevere, 2015

LED

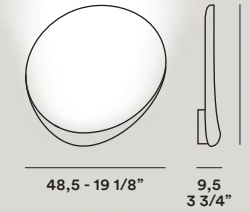

ABS stampato a iniezione.
Injection moulded ABS.

LED 13W 3000° K 850 lm included
Dimmerabile — *dimmable*
Energy class A



Avorio, rosso.
Ivory, red.



Le Soleil

Vicente Garcia Jimenez, 2013

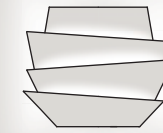

37 - 14 3/8"



14 - 5 3/8"

29 - 11 3/8"

Policarbonato stampato a iniezione e verniciato e metallo verniciato.
Injection moulded coated polycarbonate and varnished metal.

220 / 240 / 120V: fluo 2x26W G24-q3
Energy class A+, A

220 / 240V dimmerabile — *dimnable*



Bianco, acquamarina, rosso.
White, aquamarine, red.

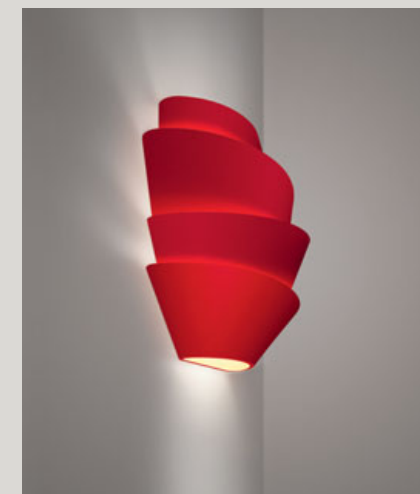

collection →



Lumiere xxl + xxs

Rodolfo Dordoni, 2010

Lumiere xxl

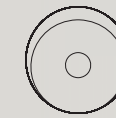

34 - 13 3/8"

13
5 1/4"

Lumiere xxs



25 - 9 5/8"

10
4 1/8"

Vetro soffiato e metallo verniciato.
Blown glass and lacquered metal.

Lumiere xxl
220 / 240V: fluo 1x40W + 1x22W 2GX13,
fluo 1x55W dimmerabile *dimnable* 2GX13
120V: fluo 1x40W 2GX13
Energy class A+, A

Lumiere xxs
220 / 240V: fluo 2x18W G24q-2
120V: fluo 2x18W G24q-2
Energy class A+, A

   IP 20
xxs 

Bianco. *White.*



collection →



p. 046

p. 252



Nuage

Philippe Nigro, 2012

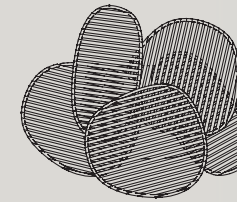

63 - 25"



34 - 13 3/8"

16 - 16 1/4"

54 - 21 1/2"

Policarbonato stampato a iniezione,
ABS masterizzato.
*Injection-moulded polycarbonate
and batch-dyed ABS.*

Utilizzabile in composizione — *Usable
in composition*

220 / 240V: fluo 1x40W + 1x22W 2GX13
fluo 1x55W dimmerabile *dimnable* 2GX13
120V: fluo 1x40W
Energy class A+, A

220 / 240V dimmerabile — *dimnable*



Bianco, verde, rosso.
White, green, red.

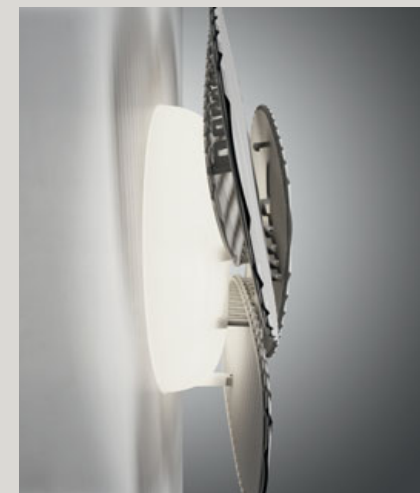

collection →



Rituals



Ludovica e Roberto Palomba, 2015

Rituals 1



Rituals 3



Rituals 1
doppia double



Rituals 3
doppia double



Vetro soffiato satinato inciso e metallo verniciato.
Blown engraved satin glass and lacquered metal.

LED E27/E26

Rituals 1 - 3
220 / 240V: halo 1x70W E27,
fluo 1x15W E27
120V: halo 1x70W E26,
fluo 1x15W E26
Energy class A+, A, B, C

Rituals 1 - 3 doppia double
220 / 240V: halo 2x70W E27,
fluo 2x15W E27
120V: halo 2x70W E26,
fluo 2x15W E26
Energy class A+, A, B, C



Bianco. *White.*



collection →

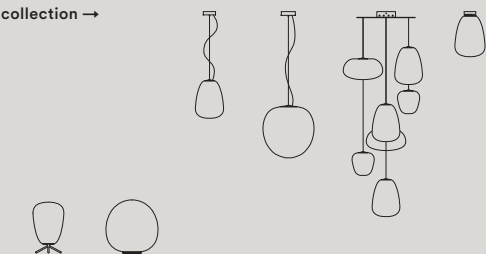

p. 058 p. 060 p. 186 p. 188 p. 214 p. 256



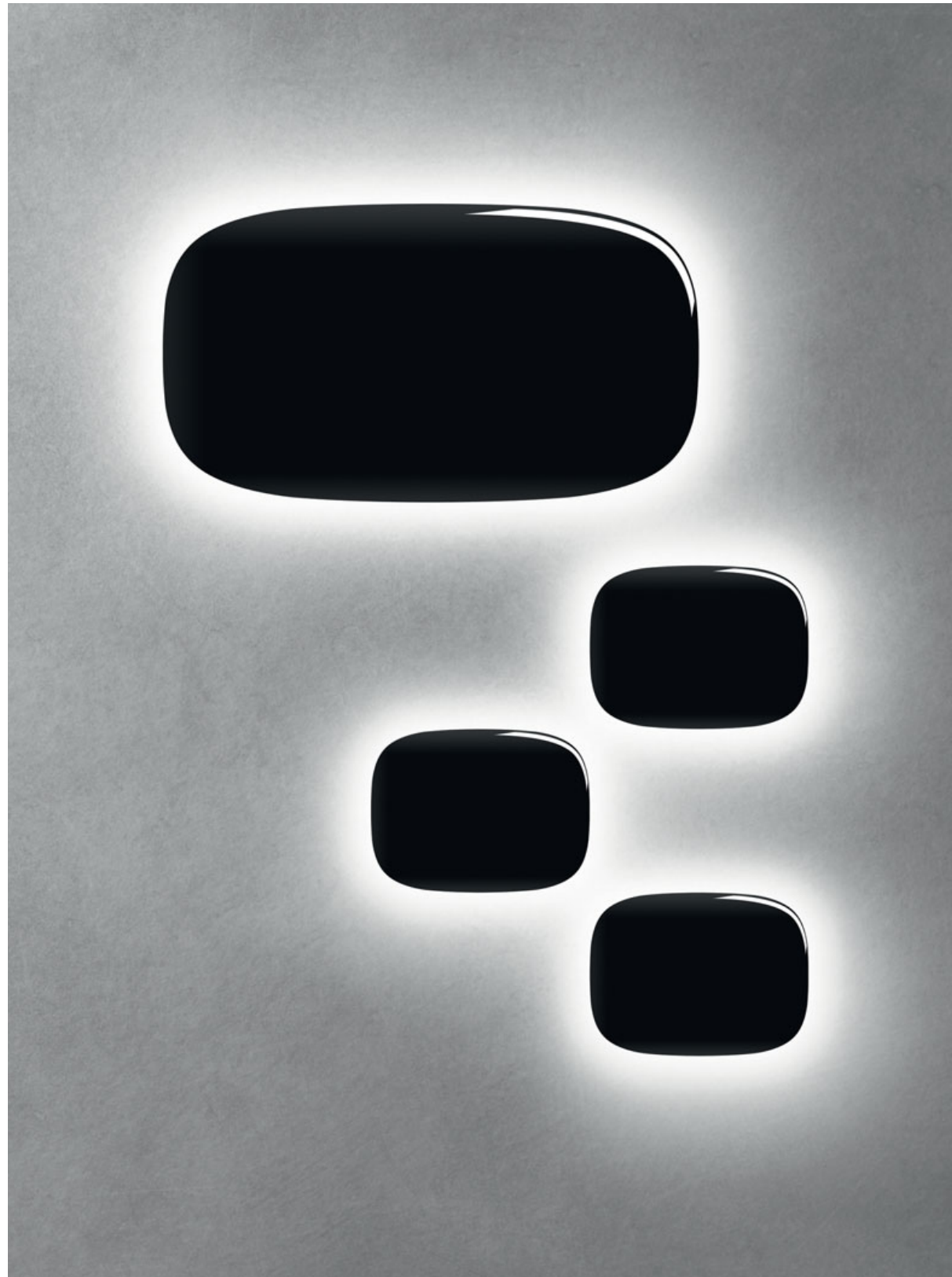

Tivu

Joseph Forakis, 2011

Tivu grande

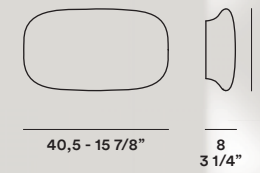

Tivu piccola

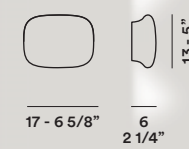

Policarbonato stampato a iniezione.
Injection moulded polycarbonate.

Tivu grande
220 / 240 / 120V: fluo 2x18W 2G11
Energy class A+, A

Anche uso in verticale — *Horizontal and vertical use*

Tivu piccola
220 / 240 / 120V: halo 1x20W G9
Energy class C



Bianco, nero.
White, black.



collection →



Tress

Marc Sadler, 2011

Tress grande

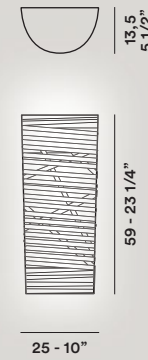

Tress piccola



Materiale composito su base di fibra di vetro verniciato e metallo verniciato.
Varnished fibreglass based composite material and varnished metal.

220 / 240V: halo 1x120W Rs7
120V: halo 1x100W RSC
Energy class C



Bianco, nero, rosso.
White, black, red.

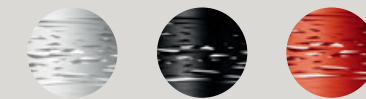

collection →

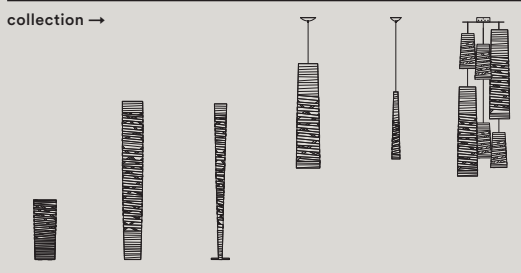

p. 062 p. 110 p. 112 p. 196 p. 200 p. 214





Tutù

Valerio Bottin, 2001

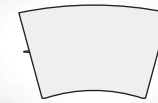

29 - 11 1/2"

18 - 7"



13 - 5"

18 - 7"

Vetro soffiato, metallo e alluminio.
Blown glass, metal and aluminium.

LED E14/E12

220 / 240V: halo 2x46W E14,
fluo 2x12W E14
120V: inc 2x40W E12,
fluo 2x13W E12
Energy class A+, A, B, C



Bianco, avorio.
White, ivory.



Esterno — *Outdoor*

- 330 **Gregg**
outdoor sospensione
- 332 **Gregg**
outdoor terra
- 334 **Havana**
outdoor sospensione
- 336 **Havana**
outdoor terra
- 338 **Solar** *outdoor*
- 340 **Uto**

Gregg *outdoor* sospensione

Ludovica e Roberto Palomba, 2011

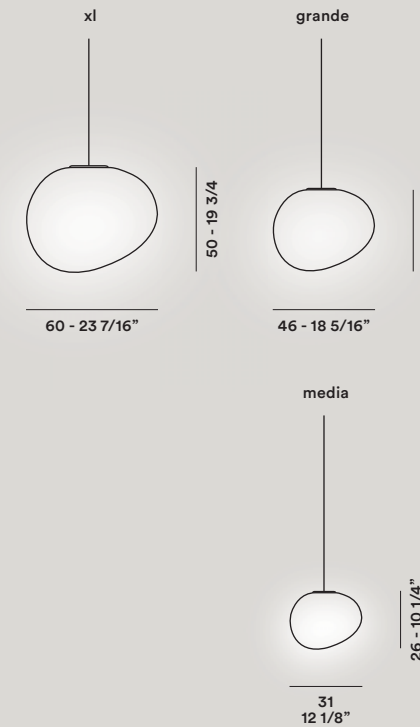

Polietilene stampato in rotazionale e metallo verniciato.
Rotational moulded polyethylene and varnished metal.

LED E27/E26

Gregg outdoor xl - Gregg outdoor grande
220 / 240V: fluo 1x25W E27
120V: fluo 1x26W E26
Energy class A+, A

Gregg outdoor media
220 / 240V: fluo 1x15W E27
120V: fluo 1x13W E26
Energy class A+, A

IP 44 IP 65

Suitable for wet location

Bianco. *White.*



collection →

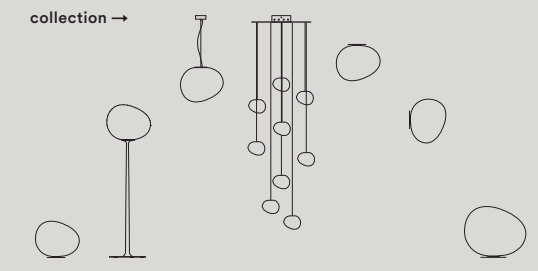

p. 036 p. 082 p. 164 p. 214 p. 250 p. 304 p. 332

Gregg outdoor terra

Ludovica e Roberto Palomba, 2011



xl

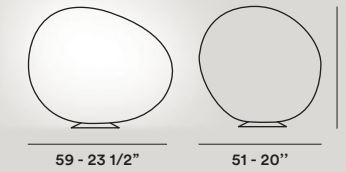

grande

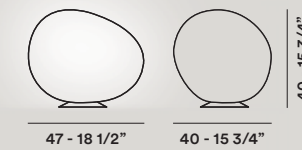

media

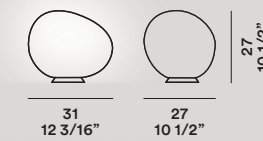

Polietilene stampato in rotazionale e metallo verniciato.
Rotational moulded polyethylene and varnished metal.

LED E27/E26

Gregg outdoor xl - Gregg outdoor grande
220 / 240V: fluo 1x25W E27
120V: fluo 1x26W E26
Energy class A+, A

Gregg outdoor media
220 / 240V: fluo 1x15W E27
120V: fluo 1x13W E26
Energy class A+, A

IP 44 IP 65

Suitable for wet location

Bianco. *White.*



collection →

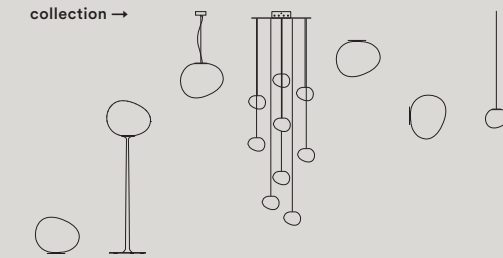

p. 036 p. 082 p. 164 p. 214 p. 250 p. 304 p. 330

Havana *outdoor* sospensione

Joseph Forakis, 2005

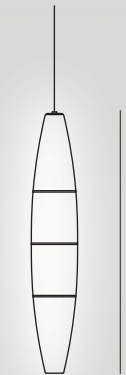

23 - 9 1/16"

130 - 51 1/8"

Polietilene stampato in rotazionale e metallo verniciato.
Rotational moulded polyethylene and varnished metal.

LED E27/E26

220 / 240V: halo 1x46W E27,
fluo 1x15W E27
120V: inc 1x60W E26,
fluo 1x13W E26
Energy class A+, A, B, C

IP 44 IP 65

Suitable for wet location

Bianco. *White.*



collection →

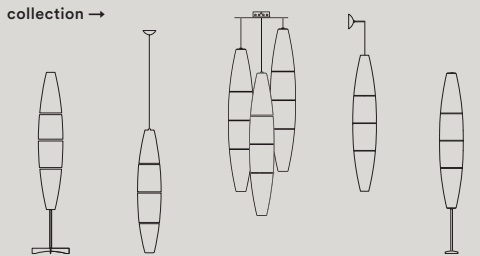

p. 088

p. 166

p. 214

p. 306

p. 336

Havana outdoor terra

Joseph Forakis, 2005

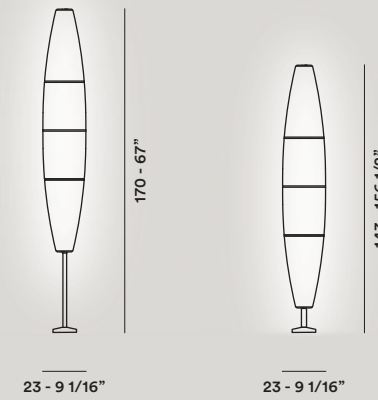

Polietilene stampato in rotazionale e metallo verniciato.
Rotational moulded polyethylene and varnished metal.

LED E27/E26

220 / 240V: halo 1x46W E27,
fluo 1x15W E27
120V: inc 1x60W E26,
fluo 1x13W E26
Energy class A+, A, B, C

IP 44 IP 65

Suitable for wet location

Bianco. *White.*



collection →

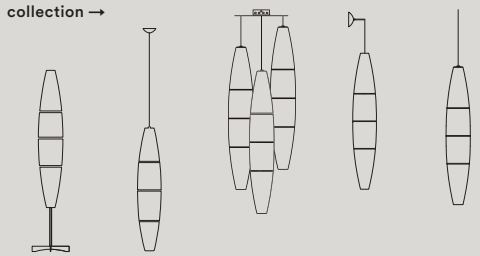

p. 088

p. 166

p. 214

p. 306

p. 334





Solar *outdoor*

Jean Marie Massaud, 2011



80 - 31 3/8"

26 - 10 1/4"
38 - 14 3/4"



15°

Polietilene stampato a rotazione,
gres e metallo verniciato.
*Rotational moulded polyethylene,
gres and varnished metal.*

LED E27/E26

220 / 240V: fluo 1x25W E27

120V: fluo 1x26W E26

Energy class A+, A



Suitable for wet location

Marrone. *Brown.*





Uto

Lagranja Design, 2005



64 - 25 5/8"

Elastomero termoplastico
e policarbonato.
*Thermoplastic elastomer
and polycarbonate.*

LED E27/E26

220 / 240V: fluo 1x15W E27
120V: fluo 1x13W E26
Energy class A+, A

☐ ⚡ IP 44

Suitable for damp location

Bianco, giallo, arancio.
White, yellow, orange.



collection →

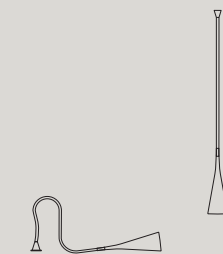

p. 066

p. 208

*Textes en français — Deutsche Texte
— Textos en español*

344 **Allegro**

344 **Bahia**

345 **Big Bang**

346 **Caboche**

346 **Fields**

347 **Havana**

348 **Lumiere**

349 **Mite**

349 **Orbital**

350 **Rituals**

351 **Tuareg**

352 **Twiggy**

Allegro —
Atelier Oi, 2007
p. 130

FR → *Allegro, une symphonie d'ombres et de lumières. Si elle peut évoquer, au premier regard, un instrument de musique ou un surprenant décor planant dans les airs, elle représente en réalité une façon très spéciale d'éclairer et de personnaliser l'espace. Allegro n'est pas une lampe, mais un projet qui associe des lignes fines réalisées avec des tiges en aluminium pour créer des formes tridimensionnelles, suspendues et immatérielles, à travers lesquelles la lumière se diffuse dans l'espace, l'habillant de subtils jeux d'ombres. Comme les notes de musique, Allegro se prête à une infinité de compositions, intimes, romantiques ou majestueuses : Allegro Ritmico, Vivace, Assai et d'autres typologies encore, pouvant être installées seules ou en série, à la maison ou dans les espaces dédiés au grand public, dans le monde entier.*

DE → *Allegro – eine Symphonie aus Licht und Schatten. Auf den ersten Blick erinnert Allegro an ein musikalisches Instrument oder eine ungewöhnliche, frei in der Luft schwebende Installation, sie ist in der Tat eine völlig neue Form der Beleuchtung und Raumgestaltung. Denn Allegro ist nicht einfach nur eine Leuchte, sondern*

vielmehr ein bezauberndes Zusammenspiel zarter Linien. Ihre dünnen Aluminiumrohre bilden dreidimensionale Formen, die wie körperlos im Raum schweben und durch die das Licht nach außen dringt und magische Schattenspiele an die Wand zeichnet. Wie aus Noten lassen sich auch aus den Allegro-Modellen eine unendliche Vielzahl verspielter, romantischer oder majestätischer Kompositionen bilden. Allegro Ritmico, Vivace, Assai wie auch die anderen eignen sich sowohl allein als auch in Kompositionen aus mehreren Leuchten hervorragend für den Einsatz in den eigenen vier Wänden und im öffentlichen Raum, in der ganzen Welt.

ESP → *Allegro, sinfonía de luz y sombras. A primera vista puede parecer un instrumento musical o una sorprendente escenografía que se lleva a cabo en el aire, pero en realidad es una forma muy especial de iluminar y caracterizar el espacio. Allegro no es una lámpara sino un proyecto que combina líneas finas, realizadas con tubos de aluminio, con formas tridimensionales, suspendidas e inmatrimales, a través de las cuales la luz se difunde en el ambiente, vistiéndolo de mágicos juegos de sombras. Como las notas musicales, Allegro se presta a infinitas composiciones íntimas, románticas o majestuosas: Allegro Ritmico, Vivace, Assai y otras tipologías, que*

se pueden ambientar solas o en grupo, en casa o en los espacios dedicados al gran público, en todo el mundo.

Bahia —
Paolo Lucidi e Luca Pevere,
2010
p. 266

FR → *Bahia, une élégance fascinante. Éclairer, mais aussi décorer un espace, avec une présence douce, poétique et infiniment séduisante, telle est la fascinante promesse de Bahia. Une harmonie d'ombres et de lumières, générée par la simple superposition de trois diffuseurs, disposés selon une asymétrie et une alternance entre surfaces concaves et convexes bien calculées, dans une forme évoquant l'image d'une île vue de haut. Entièrement blanche, pure et absolue, capable de couvrir une grande surface mais avec une épaisseur minimale, Bahia revêt une sensationnelle profondeur visuelle grâce aux leurs concentriques qu'elle émane, la lumière étant réfléchi sur le mur et diffusée dans l'espace environnant. Seule ou en composition multiple, avec la possibilité de l'orienter de différentes manières pour créer des jeux graphiques, Bahia diffuse dans chaque espace une émotion originale et une lumière séduisante.*

DE → *Bahia – Eleganz, die verzaubert. Sanft, poetisch und faszinierend.*

Mit ihrem verführerischen Licht setzt Bahia interessante Akzente und sorgt für angenehme Beleuchtung. Die drei aufeinanderliegenden Diffusoren lassen ein harmonisches Spiel von Licht und Schatten entstehen. Die asymmetrisch angeordneten, konvexen und konkaven Scheiben wecken Assoziationen an das Bild einer Insel aus Vogelperspektive. Ganz in Weiß, absolut rein und leuchtend präsentiert sich Bahia großflächig aber sie baut wenig auf. Ihre konzentrischen Lichtkreise verleihen der Leuchte eine sensationelle optische Tiefe, werden von der Wand reflektiert und sorgen so für ein angenehmes Raumlicht. Bahia macht sich gut allein, erzielt aber auch in Mehrfach-Kompositionen, etwa durch unterschiedliche Ausrichtung der einzelnen Leuchten, eine schöne Wirkung und wertet so jede Umgebung durch ihre originelle Gestalt und ihr faszinierendes Licht auf.

ESP → *Bahia, fascinante elegancia. Iluminar y al mismo tiempo amueblar un ambiente, con una presencia suave, poética e infinitamente fascinante: ésta es la seductora promesa de Bahia. Una armonía de luces y sombras, generada por la simple superposición de tres difusores, colocados siguiendo una estudiada asimetría y alternancia de superficies cóncavas y convexas, en una forma que recuerda*

una isla vista desde arriba. Completamente blanca, pura y absoluta, capaz de cubrir un área amplia pero con un grosor mínimo, Bahia asume una sensacional profundidad visual, gracias a los resplandores concéntricos que emana, reflejándose en la pared y extendiéndose en el espacio circundante. Sola o en composiciones múltiples, incluso con orientaciones diversas para crear juegos gráficos, Bahia propaga en cualquier espacio una emoción original y una iluminación fascinante.

Big Bang —
Enrico Franzolini con Vicente Garcia Jimenez, 2005
p. 142

FR → *Big Bang, une force explosive. Seule Foscarini pouvait transformer une idée aussi extrême et aussi inédite, inspirée de l'art contemporain et de l'architecture d'avant-garde, en une lampe d'un tel succès. Réalisée en méthacrylate et aluminium verni, Big Bang est une explosion de plans qui s'entrecourent, créant de multiples jeux d'ombres et de lumière, avec un éclairage à la fois direct et réfléchi. Un effet ultérieurement souligné dans la version bicolore, ou au contraire estompé dans la version monochrome, pour une lampe qui, dans tous les cas, est loin de passer inaperçue. Dans la nouvelle version à LED, la présence spectaculaire*

unique et la formidable réalisation technique s'allient à une efficacité énergétique accrue.

DE → *Big Bang – die Kraft einer Explosion. Bereits die Ausgangsidee zu Big Bang war mehr als ungewöhnlich, in dieser Form völlig neu, inspiriert von den Entwicklungen in der zeitgenössischen Kunst und modernen Architektur. Doch Foscarini wäre nicht Foscarini, würde das Unternehmen daraus nicht eine Leuchte von durchschlagendem Erfolg zaubern. Aus Methacrylat und lackiertem Aluminium gefertigt wirkt Big Bang mit ihren verschiedenen, einander überschneidenden Ebenen wie die grafische Darstellung einer Explosion. Das Ergebnis sind reizvolle Licht- und Schattenspiele und eine zugleich direkte wie auch indirekte Lichtabgabe. Ein eleganter Kontrast, der in der zweifarbigen Ausführung noch stärker zur Geltung kommt, in der einfarbigen Version hingegen etwas abgemildert wird und die Leuchte in beiden Fällen zum unwiderstehlichen Hingucker macht. In der neuen Ausführung mit LED-Beleuchtung überzeugt Big Bang neben ihrer faszinierenden Optik und unverwechselbaren Lichtwirkung zusätzlich auch mit deutlich verbesserter Energieeffizienz.*

ESP → *Big Bang, fuerza explosiva. Sólo Foscarini podía*

transformar una idea tan extrema, inédita, inspirada en el arte contemporáneo y en la arquitectura de vanguardia, en una lámpara de gran éxito. Realizada en metacrilato y aluminio pintado, Big Bang es una explosión de plataformas que se entrecruzan, creando múltiples juegos de luz y sombras, con una iluminación directa y reflejada al mismo tiempo. Un efecto que destaca todavía más en la versión bicolor, o que aparece más degradada en la monocromática, para una lámpara que, en cualquier caso, no nace para pasar desapercibida. Además, en la nueva versión de LED, a la inconfundible presencia escénica e iluminotécnica se añade una eficiencia energética todavía mayor.

Caboche —
Patricia Urquiola con Eliana Gerotto, 2005
p. 148

FR → Caboche, un bijou de design. Les femmes ont la faculté de capter les aspects les plus inattendus des choses. Quand en plus il s'agit de deux designers, leur créativité ne peut que donner naissance à une lampe aussi surprenante que séduisante : Caboche. Sa forme s'inspire d'un bracelet de perles, mais se transforme en une composition de sphères transparentes et scintillantes comme des diamants, mais réalisées à partir d'un matériau léger,

résistant et technologiquement contemporain : le polyméthilméthacrylate, en version cristal ou jaune or. Les sphères peuvent donner vie à des lampes de taille différente, du petit modèle de suspension à la grande installation, pour créer d'irrésistibles bijoux lumineux, capables d'apporter un charme précieux aux espaces les plus divers.

DE → Caboche – das Designjuwel. Frauen haben das Talent, an Dingen oft gänzlich unerwartete Seiten zu entdecken. Handelt es sich dabei noch dazu um zwei Designerinnen, kann aus ihrer gemeinsamen kreativen Arbeit gar nichts anderes entstehen als eine ebenso erstaunliche wie faszinierende Leuchte – Caboche. Ihre Form ist einem Perlenarmband nachempfunden und besteht aus einer Reihe kunstvoll arrangierter transparenter Kugeln, die wie Diamanten im Licht glitzern. Gefertigt sind diese jedoch aus leichtem, widerstandsfähigem und technologisch fortschrittlicherem Polymethylmethacrylat in den Farbausführungen klar oder goldgelb. Die Leuchte ist in verschiedenen Größen erhältlich, vom kleinen Hängeleuchtenmodell bis hin zu größeren Kompositionen, deren unwiderstehliche, leuchtende Kristalle in den unterschiedlichsten Umgebungen als eleganter Blickfang wirken.

ESP → Caboche, joya de diseño. Las mujeres saben apreciar siempre los aspectos más inesperados de las cosas. Si además se trata de dos diseñadoras, de su creatividad no pueda nacer nada más que una lámpara tan sorprendente como fascinante: Caboche. Su forma se inspira en una pulsera de perlas, pero se transforma en una composición de esferas transparentes, centelleantes como diamantes pero realizadas con un material ligero, duradero y tecnológicamente contemporáneo: el polimetilmetacrilato, en versión cristal o amarillo oro. Las esferas pueden dar vida a lámparas de diversos tamaños, del pequeño modelo de suspensión a la gran instalación, creando irresistibles joyas luminosas que añaden un encanto precioso a una gran variedad de entornos.

Fields —
Vicente Garcia Jimenez, 2007
p. 294

FR → Fields, des géométries infinies. Un projet inspiré de l'image d'une plaine vue du ciel et divisée en plusieurs champs cultivés, pour créer un système d'éclairage mural polyvalent, original et marquant. Une idée qui découle de l'observation de la nature et qui prend forme à travers un usage créatif de la géométrie et de la technologie. Que l'on recherche un design graphique discret, ou une

composition imposante, Fields permet de réaliser, à partir de trois éléments de base, utilisables individuellement ou en groupe, n'importe quelle solution d'installation. En se superposant et en s'entrecoupant, les panneaux rectangulaires en méthacrylate semi-transparent et aluminium laqué confèrent à la surface plane du mur une dimension inédite de lumières, reflets, ombres et couleurs, du blanc, pur et sculptural, aux teintes plus chaudes du rouge et de l'orange.

DE → Fields – der Charme der Geometrie. Anregung für das Design von Fields lieferte ein Blick aus dem Flugzeug auf die darunter liegenden Felder und Äcker. Das Resultat ist eine vielseitige, originelle und ausdrucksstarke Wandleuchte. Ihre konkrete Form erhielt die auf einer einfachen Naturbeobachtung basierende Idee durch das kreative Spiel mit geometrischen Prinzipien und den Einsatz moderner Technologien. Ausgehend von drei Grundelementen, die allein für sich stehen oder miteinander kombiniert werden können, lassen sich so unzählige unterschiedliche Zusammenstellungen realisieren – vom einfachen grafischen Zeichen bis hin zu komplexeren Kreationen. Die dafür verwendeten, rechteckigen Platten bestehen aus halbtransparentem Methacrylat und lackiertem Aluminium. Kreuz und quer übereinander angeordnet

verleihen sie der Lichtskulptur an der flachen Wand dimensionale Tiefe und spielen mit Reflexen, Schatten und Farben, deren Spektrum von reinem, nüchternen Weiß bis hin zu sonnigem Orange und Rot reicht.

ESP → Fields, geometrías infinitas. Un proyecto que se inspira en la imagen de una llanura subdividida en campos cultivados, vista desde una ventana de avión, para crear un sistema de iluminación de pared versátil, original y característico. Una idea que nace de la observación de la naturaleza y toma forma a través de un uso creativo de la geometría y de la tecnología. Un rasgo gráfico discreto, o bien una composición importante: Fields permite crear cualquier solución, partiendo de tres elementos de base, que se pueden utilizar solos o en grupo. Las planchas rectangulares de metacrilato semitransparente y aluminio esmaltado se superponen y se cruzan añadiendo a la lisa superficie de la pared una inédita dimensionalidad de luces, reflejos, sombras y colores: del blanco puro y escultórico a la solaridad del rojo y del naranja.

Havana —
Jozeph Forakis, 1993
p. 084

FR → Havana, une lampe révolutionnaire. Vous pouvez la rencontrer un peu partout :

dans un salon élégant, dans un établissement à la mode ou au bord d'une piscine. Fuselée comme un cigare, Havana possède un style sans âge qui lui permet de trouver sa place dans tous les espaces et de diffuser autour d'elle une lumière chaude, diffuse et solaire. Réalisée en polyéthylène blanc, un matériau léger, solide, résistant et recyclable, elle est disponible en version sur pied et à suspension, pour intérieur ou extérieur, et peut être installée seule ou en différents types de compositions. Accueillie au sein de la collection permanente du Museum of Modern Art de New York, il s'agit de l'un des plus gros succès de Foscarini, un exemple venant démontrer comment le design le plus raffiné peut se permettre une certaine forme d'accessibilité, de légèreté et d'ironie.

DE → Havana – die Revolutionäre. An den unterschiedlichsten Orten stößt man auf sie – in einem eleganten Wohnzimmer ebenso wie in einem Szenelokal oder am Rand eines Schwimmbekens. Ihre langgezogene Zigarrenform verleiht Havana eine zeitlose Optik, die sich perfekt in jedes Ambiente einfügt und ihre Umgebung mit einem warmen, diffusen, sonnigen Licht verwöhnt. Der Diffusor besteht aus weißem Polyethylen, einem leichten, langlebigen, widerstandsfähigen und recycelbarem Material.

Havana ist als Boden- wie auch als Hängeleuchte erhältlich, eignet sich sowohl für den Innen- wie auch den Außenbereich und überzeugt alleinstehend ebenso wie in Mehrfach-Kompositionen. Inzwischen hat Havana darüber hinaus auch einen festen Platz in der ständigen Ausstellung des Museum of Modern Art in New York und zählt damit unbestritten zu den absoluten Erfolgsleuchten von Foscarini. Ein schönes Beispiel dafür, dass auch raffiniertes Design auf sympathische Weise breitenwirksam funktionieren kann – mit Leichtigkeit und Ironie.

ESP → Havana, lámpara revolucionaria. Es posible encontrarla en cualquier sitio: en un elegante salón, un local de tendencia o en el borde de una piscina. Delgada como un puro, Havana tiene un estilo sin edad y se encuentra perfectamente a su gusto en cualquier ambiente, difundiendo a su alrededor una luminosidad cálida, suave y solar. Se realiza en polietileno blanco: un material ligero, duradero, resistente y reciclable. Se encuentra disponible en versión de tierra y de suspensión, para internos o externos y se ambienta sola o en fascinantes composiciones múltiples. Forma parte de la colección permanente del Museum of Modern Art de Nueva York y es uno de los mayores éxitos de Foscarini: un ejemplo que demuestra que incluso el

diseño más refinado puede permitirse un agradable sabor de accesibilidad, ligereza e ironía.

Lumiere —
Rodolfo Dordoni, 1990
p. 038

FR → Lumiere, l'inévitable best-seller. Depuis sa naissance au XVII^{ème} siècle à Paris, l'abat-jour est passé par d'innombrables interprétations. Puis en 1990, la rencontre entre un designer et une entreprise italienne donne vie à une idée neuve dans le monde de l'éclairage : Lumiere. Une relecture érudite et raffinée de l'abat-jour classique, avec un précieux diffuseur en verre soufflé, associé à un trépied unique en aluminium moulé sous pression. Pour son 25^{ème} anniversaire, Lumiere se présente dans une édition spéciale, avec une finition métalisée du verre qui laisse entrevoir comme par magie l'ampoule placée à l'intérieur. Pour le modèle d'origine aussi, Foscarini ajoute une nouvelle couleur pour la base et trois nouveaux tons pour le diffuseur, avec un traitement qui produit une lumière encore plus douce et chaude. De nouveaux coloris existent également pour la base et le diffuseur des versions XXL et XXS. Lumiere a toujours une histoire merveilleuse et différente à raconter.

DE → Lumiere – der

unverwechselbare Bestseller. Im 17. Jahrhundert entstanden in Paris die ersten Tischleuchten – seither wurde diese Form immer wieder neu interpretiert. Im Jahr 1990 wurde schließlich bei einem Treffen zwischen einem Designer und einem italienischen Unternehmen eine in der Welt der Beleuchtung bisher nie da gewesene Idee geboren. Lumiere. Eine raffinierte und elegante Neuinterpretation der klassischen Tischleuchten mit einem kostbaren Diffusor aus geblasenem Glas. Als Stütze für den Schirm dient ein charakteristischer Dreifuß aus druckgegossenem Aluminium. Zu seinem 25-jährigen Jubiläum ist Lumiere ab nun zudem in einer Sonderausgabe mit metallisierter Oberfläche erhältlich, die auf magische Weise die Lichtquelle im Inneren der Leuchte durch das Glas schimmern lässt. Und auch das Originalmodell präsentiert sich in festlichem Look – mit einer neuen Farbe für das Gestell und drei neuen Varianten des Diffusors, der in der aktuellen Ausführung ein noch weiches und wärmeres Licht verströmt. Gleiches gilt auch für die Modelle XXL und XXS. Lumiere – Vielfalt, die verzaubert.

ESP → Lumiere, imperdible best-seller. Las pantallas para lámparas nacieron en el siglo XVII en París y, desde entonces hasta nuestros días, han atravesado innumerables interpretaciones. En el año

1990, del encuentro entre un diseñador y una empresa italiana, nació una idea nueva en el mundo de la iluminación: Lumiere. Una relectura culta y refinada de la clásica pantalla, con un precioso difusor en vidrio soplado junto con un inconfundible trípode en aluminio fundido bajo presión. En el 25 aniversario de su creación, Lumiere se presenta en una edición especial, con un tratamiento metalizado del vidrio que deja entrever mágicamente la fuente luminosa situada en el interior. También el modelo original añade un nuevo color a la base y tres nuevas tonalidades para el difusor, con un tratamiento que hace que la luz sea más suave y cálida. Nuevos colores para la base y el difusor también para las versiones XXL y XXS. Lumiere dispone siempre de una historia espléndida y distinta para contar.

Mite —
Marc Sadler, 2000
p. 094

FR → Mite, une personnalité unique. Élançée, élégante, importante et unique, allumée comme éteinte. Une forme sinueuse, revêtue d'une trame de verre, un matériau à la tradition millénaire, et fil de carbone ou Kevlar®, les mêmes fibres technologiques que celles utilisées pour créer des bateaux à voile et des clubs de golf. Une innovation

absolue qui a valu à Mite, et à la version suspendue de Tite, le prix du Compasso d'Oro en 2001, une des reconnaissances les plus prestigieuses du monde. Une lampe qui est devenue une icône dans le paysage de l'éclairage et qui exprime maintenant, dans sa nouvelle version à LED, une luminosité encore plus fascinante, avec en plus l'avantage d'une technologie respectueuse de l'environnement.

DE → Mite – einfach legendär. Schlank, elegant, stattlich und ob an oder aus einfach unverwechselbar. Die geschwungene Form von Mite besteht aus einem Mischgewebe aus Glas, Material mit jahrtausendealter Tradition, und Carbonfasern oder Kevlar®-Band, denselben Technofasern, aus denen auch Segelboote und Golfschläger gefertigt werden. Eine absolute Innovation, die im Jahr 2001 Mite – zusammen mit der Ausführung als Hängeleuchte Tite – einen der renommiertesten Designpreise der Welt, den begehrten Compasso d'Oro eingebracht hat. Mittlerweile gilt die Leuchte im Beleuchtungssektor als Designikone. Die neue LED-Ausführung besticht durch noch schönere Lichtabgabe und den Vorteil eines umweltfreundlichen Innenlebens.

ESP → Mite, personalidad mítica. Esbelta, elegante, importante, inconfundible

tanto encendida como apagada. Una forma sinuosa, vestida con una malla de vidrio, un material de tradición milenaria, e hilo de carbono o de Kevlar®, las mismas fibras tecnológicas utilizadas para crear barcos de vela y palos de golf. Una innovación absoluta que le ha valido a Mite, junto con la versión de suspensión Tite, el Compasso D'Oro 2001, uno de los premios más prestigiosos del mundo. Una lámpara que se ha convertido en un icono en el panorama de la iluminación y que ahora, en la nueva versión de LED, expresa una luminosidad todavía más fascinante, con además la ventaja de contar con una tecnología amiga del medio ambiente.

Orbital —
Ferruccio Laviani, 1992
p. 102

FR → Orbital, une sculpture domestique. Est-ce une lampe, ou une installation artistique ? Considérée dès son lancement en 1991 comme un objet unique dans l'univers du design, possédant même un timbre à son effigie, Orbital est peut-être bien les deux à la fois. Une composition de silhouettes en verre sérigraphié, inspirées des formes des galaxies, montées sur une structure en métal laqué et à l'esprit industriel. Blanche ou multicolore, Orbital diffuse un signal visuel unique dans l'espace environnant, avec une luminosité et une

forme esthétique absolument originale. Les ampoules apparentes sont en effet un élément à part entière de l'esthétique de cet objet qui exprime toute la créativité et la culture typiquement italienne du design.

DE → *Orbital* – Skulptur für die eigenen vier Wände. Leuchte oder Kunstwerk? Vielleicht auch beides. Denn seit *Orbital* 1991 in den Handel kam, gilt die Leuchte in der Welt des Designs als absolut einzigartig und schaffte es sogar auf eine Briefmarke. Auf ihrem industriell wirkenden Gestell aus lackiertem Metall sind eine Reihe unterschiedlicher sieb-bedruckter Glasscheiben befestigt, deren Gestalt an die Form von Galaxien erinnert. Erhältlich in den Ausführungen weiß oder multicolor setzt *Orbital* in beiden Varianten spannende optische Akzente und verzaubert sowohl durch ihre sonderbare Gestalt als auch durch ihr ungewöhnliches Licht. Die sichtbar montierten Lampen sind wesentlicher Bestandteil des Designs der Leuchte, als Ausdruck typisch italienischer Kreativität und Formensprache.

ESP → *Orbital*, escultura doméstica. ¿Es una lámpara o una instalación artística? Lanzada en el 1991, considerada desde su aparición como un objeto único en el universo del diseño, representada incluso en un sello, *Orbital* es quizás las

dos cosas. Una composición de plantillas en vidrio serigrafiado, inspiradas en las formas de las galaxias, sobre una estructura de metal esmaltado de sabor industrial. Blanca o multicolor, *Orbital* propaga una señal visual inconfundible en el espacio a su alrededor, con una luminosidad y una forma estética absolutamente especiales. Las bombillas a vista son en efecto un elemento que integra el diseño de esta obra, la expresión de una creatividad y una cultura del proyecto típicamente italiana.

Rituals —
Ludovica e Roberto
Palomba, 2013
p. 054

FR → *Rituals*, des lanternes modernes. Les lampes *Rituals*, dont la forme s'inspire des lanternes en papier de riz de la culture orientale, mais réalisées en verre soufflé, un matériau occidental précieux à la tradition millénaire, parlent un langage atemporel et sans frontière, celui de la beauté, de la poésie et de la liberté de combinaison et d'installation. Différentes mais complémentaires dans leur forme, elles forment une famille complète (des modèles à suspension aux versions de table, en passant par les appliques et les plafonniers), qui permet de créer une multitude de compositions, avec la possibilité d'associer

jusqu'à 9 suspensions grâce au cache multiple. Avec leur surface parcourue de fines incisions évoquant à la fois la texture du papier crêpé et le meulage du verre, elles émettent une lumière diffuse, intime et caressante, idéale pour accompagner les multiples rituels de la vie domestique contemporaine.

DE → *Rituals* – moderne Laternen. Angelehnt an die zarten Formen orientalischer Reispapierlaternen und gefertigt aus kostbarem, mundgeblasenem Glas jahrtausendealter westlicher Tradition bestechen die Leuchten der Serie *Rituals* durch ihr zeitloses Design und ihre allgemeingültige Ästhetik. Ihre elegante, poetische Gestalt lässt sich gut kombinieren und fügt sich perfekt in jedes Ambiente. Ihre unterschiedlichen Formen ergänzen einander und erlauben eine Vielzahl interessanter Zusammenstellungen. Die Leuchtenfamilie umfasst Hänge-, Tisch-, Wand- und Deckenleuchten und bietet darüber hinaus die Möglichkeit, mittels Mehrfach-Baldachin Kompositionen mit bis zu 9 Hängeleuchten zu kreieren. Die zart gerillte Oberfläche von *Rituals* erinnert zugleich an zerknittertes Papier und geschliffenes Glas, sorgt für ein diffuses, warmes und anheimelndes Licht und macht die Leuchte zu einem angenehmen Begleiter durch den modernen Wohnalltag.

ESP → *Rituals*, faroles modernos. Inspiradas en la forma a los ligeros faroles de papel de arroz de la cultura oriental, pero realizadas en precioso vidrio soplado, material de tradición occidental milenaria, las lámparas *Rituals* hablan un lenguaje sin tiempo y sin fronteras, el de la belleza, la poesía y la libertad de combinar y ambientar. Sus formas, distintas pero complementarias, generan una familia completa y permiten dar vida a múltiples composiciones, oscilando entre modelos de suspensión y de mesa, pared, techo, con además la posibilidad de componer hasta 9 suspensiones gracias al florón múltiple. Su superficie, recorrida por finas incisiones que recuerdan al mismo tiempo la ondulación del papel y el pulido del vidrio, propaga una luz suave, íntima y agradable, ideal para acompañar los múltiples rituales de la forma de vivir contemporánea.

Tuareg —
Ferruccio Laviani, 2013
p. 114

FR → *Tuareg*, une nouvelle forme d'éclairage. Une lampe sur pied inspirée des structures primitives réalisées par les civilisations tribales à partir de branches ou de cannes de bambou, pour donner naissance à une architecture surprenante, innovante,

chaotique en apparence, mais en réalité extrêmement fonctionnelle. *Tuareg* est formée d'un ensemble de tubes en aluminium laqué de noir ou orange, composant une géométrie tridimensionnelle, avec des ampoules à LED pouvant s'allumer d'un simple geste grâce aux interrupteurs tactiles intégrés et s'orienter de manière indépendante à 360°, pour créer d'infinies possibilités d'éclairage. La forme et la lumière, mais aussi la couleur, ont un rôle important puisque *Tuareg* présente un élégant habit noir adapté à toutes les occasions, ou un orange brillant évoquant les contextes industriels, pour des environnements non conventionnels.

DE → *Tuareg* – neue Wege der Beleuchtung. Das Design der Bodenleuchte nimmt Anlehnung an primitiven Konstruktionen aus zusammengebundenen Zweigen oder Bambusrohren. Das Ergebnis ist eine außergewöhnliche, innovative Formensprache, scheinbares Chaos, das jedoch maximale Funktionalität garantiert. *Tuareg* besteht aus schwarz oder orangefarben lackierten Aluminiumrohren, die eine dreidimensionale geometrische Figur bilden. Die darin untergebrachten LED-Lampen lassen sich dank integrierter Touch-Schalter mit einer einfachen Handbewegung ein- und ausschalten. Darüber hinaus können die Lampen unabhängig voneinander

um 360° gedreht werden und ermöglichen damit eine Vielzahl unterschiedlicher Beleuchtungsszenarien. Aber nicht nur Form und Licht, auch der Wahl der Farbe kommt bei *Tuareg* eine entscheidende Rolle zu. Schwarz und elegant fügt sich die Leuchte dezent in jedes Ambiente, in leuchtendem Orange hingegen tritt ihr industrieller Charakter in den Vordergrund, ideal für den Einsatz in unkonventionellen Umgebungen.

ESP → *Tuareg*, nueva forma de iluminación. Una lámpara de pie que se inspira en las primitivas estructuras realizadas en las culturas tribales, uniendo ramas o cañas de bambú, para dar vida a una arquitectura sorprendente, innovadora, sólo aparentemente caótica pero en realidad sumamente funcional. *Tuareg* está formada por tubos en aluminio, pintados de negro o naranja, que componen una geometría tridimensional, con luces de LED que se pueden encender con un simple gesto, gracias a los interruptores "touch" integrados, y que se pueden orientar a 360° de forma independiente, para crear infinitas posibilidades de iluminación. No sólo la forma y la luz sino también el color tiene un papel importante en *Tuareg*: un elegante traje negro adecuado para cualquier ocasión, o bien un naranja brillante que recuerda situaciones industriales, para ambientes no convencionales.

Twiggy —
Marc Sadler, 2006
p. 120

FR → Twiggy, tout simplement géniale. Imaginez une ligne fine, flexible et arquée qui, comme par magie, soutiendrait dans l'air un large diffuseur pouvant éclairer simultanément vers le bas grâce à une lumière directe, et vers le haut grâce à une lumière diffuse. C'est fait ? Et bien vous venez d'imaginer Twiggy, une lampe qui allie la recherche d'une simplicité absolue aux possibilités offertes par les matériaux contemporains. Twiggy se plie harmonieusement telle une canne à pêche. Elle est par ailleurs réglable en hauteur pour répondre à tous les besoins. À côté d'un canapé ou d'une chaise-longue, au-dessus d'une table ou d'un bureau, seule, telle une marque unique et reconnaissable dans l'espace, ou en composition, elle se distingue toujours par une personnalité et une flexibilité extrême.

DE → Twiggy – einfach genial. Eine hauchdünne Linie, elastisch geschwungen, die wie von Zauberhand einen großen Diffusor in der Luft hält, aus dem direktes Licht nach unten und diffuses Licht nach oben strahlt. Das ist Twiggy. Elegante Symbiose maximaler Schlichtheit mit den Möglichkeiten moderner Materialien. Wie eine Angelrute neigt sich Twiggy sanft nach vorne und lässt

sich dabei je nach Bedarf in der Höhe verstellen. Wunderschön neben einem Sofa oder einer Chaiselongue, über einem Tisch oder Arbeitsplatz macht die Leuchte sowohl allein, als optischer Akzent im Raum, wie auch in effektvollen Kompositionen schöne Figur und überzeugt durch ihre außergewöhnliche Formensprache und Flexibilität.

ESP → Twiggy, simplemente genial. Imagínese una línea muy fina, flexible y arqueada que, como por arte de magia sostiene en el aire un amplio difusor que ilumina al mismo tiempo hacia abajo con una luz directa y hacia arriba con una luz suave. ¿Ya está? Pues bien, acaba de imaginarse a Twiggy, una lámpara que une la búsqueda de una sencillez absoluta con las posibilidades ofrecidas por los materiales contemporáneos. Como una caña de pescar, Twiggy se dobla de forma armoniosa y además se puede regular en altura para satisfacer las necesidades de ambientación. Al lado de un sofá o una tumbona, encima de una mesa o un escritorio, sola como un rasgo inconfundible en el espacio o en escenográficas composiciones, pero siempre con una excepcional personalidad y flexibilidad.

Legenda — Key

LED

Identifica i modelli con LED integrati e già inclusi, risultato della progettazione ed ingegnerizzazione Foscarini.

It marks the models with integrated LED included in the lamp, which is the result of Foscarini designing and engineering.

Identifie les modèles avec source LED intégrée, résultant de la conception et de l'ingénierie Foscarini.

Kennzeichnet die Modelle mit integrierter LED-Quelle, stammend aus der Foscarini Entwurfs- und Entwicklungsarbeit.

Identifica los modelos con LED integrados y ya incluidos, resultado del proyecto y de la ingeniería Foscarini

LED Retrofit

Identifica la possibilità di utilizzare una lampadina LED retrofit standard comunemente disponibile sul mercato.

It marks the possibility of using a standard retrofit LED bulb available on the market.

Identifie la possibilité d'utiliser une ampoule LED retrofit, qui peut être aisément réparée sur le marché.

Kennzeichnet die Möglichkeit, ein LED Retrofit Leuchtmittel einzusetzen, was auf dem Markt leicht zu finden ist.

Identifica la posibilidad de utilizar una bombilla LED retrofit estándar comúnmente disponible en el mercado.

CSQ - IQNET

Marchio valido in tutto il mondo, certifica che l'azienda Foscarini attua un sistema di gestione della qualità conforme alla normativa UNI EN ISO 9001:2008, per garantire un elevato standard qualitativo nella progettazione, sviluppo, fabbricazione e commercializzazione dei propri prodotti.

The CSQ-IQNET label is valid all over the world. It certifies that Foscarini runs a quality management system which complies with the UNI EN ISO 9001:2008 standard, to guarantee a high quality level for what concerns project, development, production and distribution of its products.

Le label CSQ-IQNET est reconnu dans le monde entier et certifie que Foscarini met en place un système de gestion de la qualité conforme à la norme UNI EN ISO 9001:2008 pour garantir un niveau de qualité élevé dans l'ensemble de la conception, développement, production et vente de ses appareils d'éclairage.

Das CSQ-IQNET Prüfzeichen ist weltweit anerkannt und zertifiziert, daß Foscarini ein der Norm UNI EN ISO 9001:2008 entsprechendes Qualitätssystem anwendet, um ein hohes Qualitätsniveau in Hinblick auf Planung, Entwicklung, Produktion und Vertrieb der eigenen Produkte zu gewährleisten.

La marca CSQ-IQNET es válida en todo el mundo y certifica que Foscarini tiene un sistema de calidad conforme a la norma UNI EN ISO 9001:2008 para garantizar un elevado nivel de calidad en la proyección, el desarrollo, la producción y la venta de sus productos.

CSQ ECO

Marchio valido in tutto il mondo, certifica che l'azienda Foscarini attua un sistema di gestione ambientale conforme alla normativa UNI-EN ISO 14001:2004 per garantire l'impegno dell'azienda ad operare nel rispetto dell'ambiente e con l'obiettivo continuo di ridurre l'impatto delle proprie attività.

This label is valid all over the world. It certifies that Foscarini runs an environmental management system which complies with the UNI EN ISO 14001:2004 standard in order to guarantee company's commitment to continual improvement of its environmental performances.

Le label est reconnu dans le monde entier et certifie que Foscarini met en place un système de management environnemental conforme à la norme UNI EN ISO 14001:2004 pour garantir l'engagement de l'entreprise à agir dans le respect de l'environnement avec le but de réduire constamment l'impacte environnemental de ses activités.

Das Prüfzeichen ist weltweit anerkannt und zertifiziert, daß Foscarini ein der Norm UNI EN ISO 14001:2004 entsprechendes Umweltmanagementsystem anwendet, um die betriebliche Verpflichtung zum Umweltschutz, mit dem Ziel der stetigen Verbesserung ihrer Umweltleistungen zu be-

La marca es válida en todo el mundo y certifica que Foscarini tiene un sistema de gestión ambiental conforme a la norma UNI EN ISO 14001:2004 para garantizar el compromiso de la empresa a trabajar respetando el ambiente y con el objetivo de seguir reduciendo el impacto de sus actividades.

ENEC 15

Il marchio ENEC (Certificazione Elettrica relativa alle Norme Europee) è un marchio volontario rilasciato da enti terzi. Certifica che il prodotto è conforme e rispetta i requisiti proposti dalla norma EN 60598 ed è progettato e realizzato in aziende il cui sistema di gestione della qualità soddisfa i requisiti della norma UNI EN ISO 9001.

The label ENEC (Electrical Certification concerning European Standard) is a voluntary label granted by third organizations. It certifies that a product complies with the EN 60598 standards and has been designed and manufactured by companies with an approved UNI EN ISO 9000 quality control system.

Le label ENEC (Certification Electrique relative aux Normes Européennes) est volontaire et issu par des établissements tiers. Il certifie qu'un produit est conforme à la norme EN 60598 et qu'il a été conçu et fabriqué par des entreprises dotées d'un système de qualité conforme aux normes UNI EN ISO 9000.

Das Prüfzeichen ENEC (Elektrische Zertifizierung in Bezug auf die Europäischen Normen) ist eine freiwillige Zertifizierung die von Dritten gewährt wird. Es zertifiziert, dass ein Produkt den Vorgaben der EN 60598 Norm entspricht und von Firmen entwickelt und hergestellt wird, deren Qualitätsmanagement den Normen UNI EN ISO 9000 entspricht.

La marca ENEC (Certificación Electrica relativa a las normas Europeas) es voluntaria y entregada por empresas terceras. Certifica que un producto cumple a la norma EN 60598 y ha sido proyectado y realizado por empresas con un sistema de calidad conforme a las normas UNI EN ISO 9000.

Legenda — Key

Classe I

Apparecchio in classe I°: è obbligatoria la connessione al conduttore di protezione giallo/verde (messa a terra).

Class I° luminaire: it's necessary to connect the device to the yellow/green protective conductor (earthing).

Il est obligatoire la connexion au conducteur de protection jaune/vert (mise à la terre).

Alle berührbaren Metallteile sind elektrisch leitend miteinander verbunden und werden mit dem Netz-Schutzleiter verbunden.

Aparato en el que: es obligatoria la conexión al conductor de protección Amarillo/verde (toma de tierra).

cULus

Certifica che il prodotto è conforme e rispetta i requisiti proposti dalle normative nordamericane, viene rilasciato dall'UL, organizzazione indipendente leader nel settore della certificazione di sicurezza dei prodotti destinati al mercato Nordamericano.

Certifies that the product is conform to the North American standards, and is issued by UL, independent organisation leader in the field of products safety certification for the North American market.

Certifie que le produit est conforme aux normes nordaméricaines et est issu par UL, une organisation indépendante leader dans le secteur de la certification de sécurité des produits destinés au marché nordaméricain.

Zertifiziert, dass das Produkt den nordamerikanischen Normen entspricht und wird von UL, einer unabhängigen, im Bereich der Produktsicherheitszertifizierung für den nordamerikanischen Markt führenden Organisation ausgestellt.

Certifica que el producto cumple a las normas norteamericanas y es entregado por UL, la mas importante organización independiente de certificación de seguridad de los productos para el mercado estadounidense y canadiense.

Classe II

Apparecchio in cui la protezione contro la scossa elettrica si basa unicamente sul doppio isolamento e/o isolamento rinforzato in ogni parte e senza dispositivo di messa a terra.

Light fittings whose safety is guaranteed only by the double and/or reinforced insulation of all parts, with no earth.

Appareil où la sécurité électrique est garantie par un double niveau d'isolation de toutes les parties sans dispositif de mise à la terre.

Bei Leuchten der Klasse II ist der Berührungsschutz durch eine doppelte und /oder verstärkte Schutzisolierung aller spannungführenden Teile gegeben, ohne Erdung.

Aparatos con protección contra descargas eléctricas basados en un doble aislamiento o un aislamiento reforzado, sin dispositivo de toma de tierra.

CCC

The China Compulsory Certificate mark certifies that the product is conform to the Chinese standards.

The China Compulsory Certificate mark certifies that the product is conform to the Chinese standards.

The China Compulsory Certificate mark certifies that the product is conform to the Chinese standards.

The China Compulsory Certificate mark certifies that the product is conform to the Chinese standards.

The China Compulsory Certificate mark certifies that the product is conform to the Chinese standards.

Americans Disability ACT

Serie di normative che regolano l'arredo di edifici pubblici a favore dei portatori di handicap.

Certification that confirms accessibility to places of public accommodation and commercial facilities by individuals with disabilities.

Une série de normes concernant la décoration des collectivités en faveur des handicapés.

Eine Reihe von Vorschriften für öffentliche Gebäude zugunsten der Behinderten.

La Ley de Estadounidenses con Discapacidades incluye una serie de normas que regulan la decoración de los edificios públicos a favor de los minusválidos.

Legenda — Key

IP

IP Protection Degree

IP20: apparecchio protetto contro la penetrazione di corpi solidi di dimensioni maggiori a 12mm e non protetto nei confronti dei liquidi.

IP44: apparecchio protetto contro la penetrazione di corpi solidi di dimensioni maggiori a 1mm e protetto contro gli spruzzi d'acqua.

IP65: apparecchio totalmente protetto contro la polvere e protetto contro i getti d'acqua.

IP20: protected against the penetration of solid objects greater than 12 mm and non protected against liquids.

IP44: protected against the penetration of solid objects greater than 1 mm and protected against splashing water.

IP65: dust-tight and protected against water jets.

IP20: protégé contre la pénétration des corps solides aux dimensions supérieures à 12 mm, sans protection contre les liquides.

IP44: protégé contre la pénétration des corps solides aux dimensions supérieures à 1 mm et protégé contre les projections d'eau de toutes directions.

IP65: protégé contre la pénétration de poussière et protégé contre les jets d'eau de toutes directions.

IP20: Gegen das Eindringen von Festkörpern größer als 12 mm geschützt, ohne Schutz gegen Flüssigkeiten.

IP44: Gegen das Eindringen von Festkörpern größer als 1 mm und gegen das Eindringen von Spritzwasser geschützt.

IP65: Staubdicht und gegen das Eindringen von Spritzwasser geschützt.

IP20: protección contra la penetración de cuerpos sólidos de un tamaño superior a 12 mm, sin protección contra líquidos.

IP44: protección contra la penetración de cuerpos sólidos de un tamaño superior a 1 mm y protección contra las salpicaduras de agua.

IP65: protección total contra el polvo y protección contra los chorros de agua.

Energy Efficiency Classes

Le classi di efficienza energetica degli apparecchi luminosi, definite dal reg. UE n.874/2012, sono determinate in base all'Indice di Efficienza Energetica (IEE) e spaziano in un intervallo compreso tra A++ (efficienza massima) ed E (efficienza minima).

The energy efficiency classes for light appliances set out by EU regulation no. 874/2012 are calculated on the basis of the Energy Efficiency Index (EEI) and range between A++ (maximum efficiency) and E (minimum efficiency).

Les classes d'efficacité énergétique des appareils lumineux, définies par le règlement UE n° 874/2012, sont déterminées en fonction de l'indice d'efficacité énergétique (IEE) et représentent une échelle allant d'A++ (efficacité maximale) à E (efficacité minimale).

Energie Effizienz Klassen. Die von der EU-Verordnung 874/2012 definierten Energieeffizienzklassen für Leuchten werden auf Grundlage des Energieeffizienzindex (EEI) ermittelt und reichen von A++ (maximale Effizienz) bis E (geringste Effizienz).

Las clases de eficiencia energética de los aparatos luminosos, definidas por el reglamento UE n.º 874/2012, están determinadas según el Índice de Eficiencia Energética (IEE) y oscilan en un intervalo comprendido entre A++ (eficiencia máxima) y E (eficiencia mínima).

Colophon

Foscarini SpA
via delle Industrie 27
30020 Marcon / Venezia / Italy
T +39 041 595 3811
F +39 041 595 3820
foscarini@foscarini.com

Foscarini Inc
17 Greene Street, New York
NY /10013 / USA
T +1 212 247 2218
F +1 646 545 2564
foscarini.inc@foscarini.com

Foscarini Spazio Brera
via Fiori Chiari 28 /
via Pontaccio 19
20121 / Milano / Italy
T +39 02 870 71320
spaziobrera@foscarini.com

Foscarini Spazio Soho
17 Greene Street, New York
NY /10013 / USA
T +1 212 257 4412
spaziosoho@foscarini.com

Azienda certificata
UNI EN ISO 9001
UNI EN ISO 14001

edizione 04.2015

Concept and graphic design:
Designwork
art direction: Artemio Croatto
art work: Erika Pittis / Designwork

photography:
Massimo Gardone / Azimut
Gianluca Vassallo → inserto p. 016.
Tommaso Sartori → p. 001, 002, 016,
018, 038, 070, 094, 114, 128, 130, 148,
212, 228, 262, 328, 332, 342, 360.
Kasia Gatkowska → p. 102.
Andrea Ferrari → p. 120, 172, 266, 302.
Alessandro Paderni → p. 054, 198, 208,
214, 264, 298, 308, 318, 330, 334, 336,
338, 340.

colour separation:
Luce, Udine
made and printed in Italy
by OGM, Padova

foscarini.com

